

Manual for Swema 3000



Version 0903 5.10



Swema AB
Tel: +46 8 94 00 90

Pepparvägen 27
Fax: +46 8 93 44 93

SE-123 56 FARSTA
swema@swema.se

www.swema.com

Contents

Connectors and Buttons	3
How to put on/off holders for the probes	4
Starting	5
PC programs	6
The different probes for Swema 3000	7
The different modes used in Swema 3000	9
Measuring with APF (Average Point air Flow)	10
Recomended measuring points for circular and rectangular ducts	11
Measuring with DPF (Differential Pressure air Flow)	13
Measuring with AF (Average Flow)	15
Measuring with BP (Back Pressure)	16
Measuring with AP (Average Point)	18
Measuring with AS (Auto Sampling)	19
Measuring with ASF (Auto Sampling Flow)	20
Measuring with CO (Comfort)	22
Measuring with LOG (Logging)	23
Measuring with LOGP (Logging Protocols)	24
Note Book, Log Book and File	25
Leakage tester for Building	26
Leakage tester for Duct	28
Control unit for leakage tester	30
Measuring with SwemaTwin - Balancing of ventilation	31
Menu 1	32
Menu 2	33
Menu 3	34
SwemaTerminal/SwemaUSB	35
Time constant	36
Displayed values and saving measurment	36
Technical Data	37

Connectors and Buttons



Probe connector

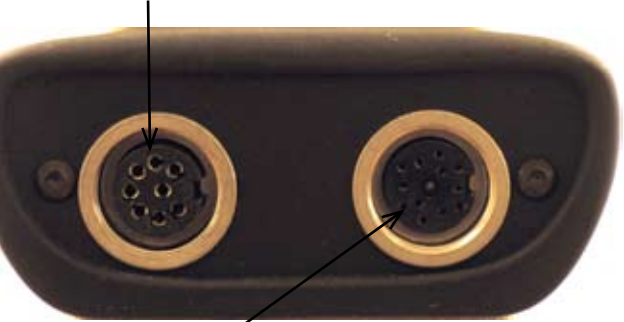

RS232/SwemaTwin connector

USB connector

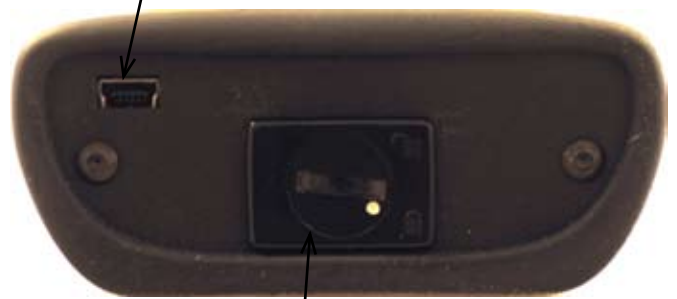

Battery hatch 2 x AA Batteries

SWA 31

Display

Menu-keys

Arrow Keys

Enter Key

Display light

On / Off

How to put on/off holders for the probes

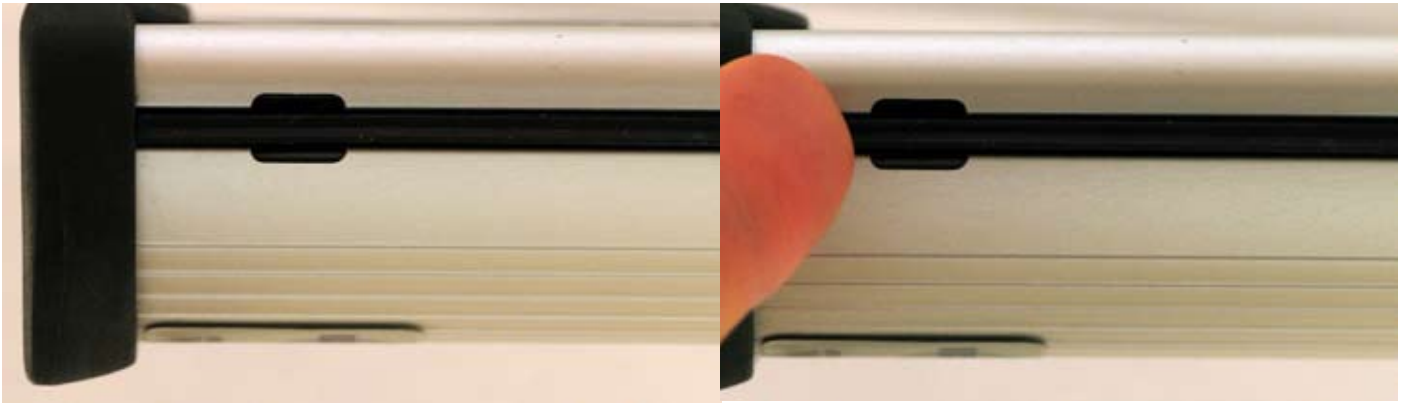

Start with removing the rubber strip by gripping it with your fingers. Pull it up about 1 cm to the opening and pull it out.

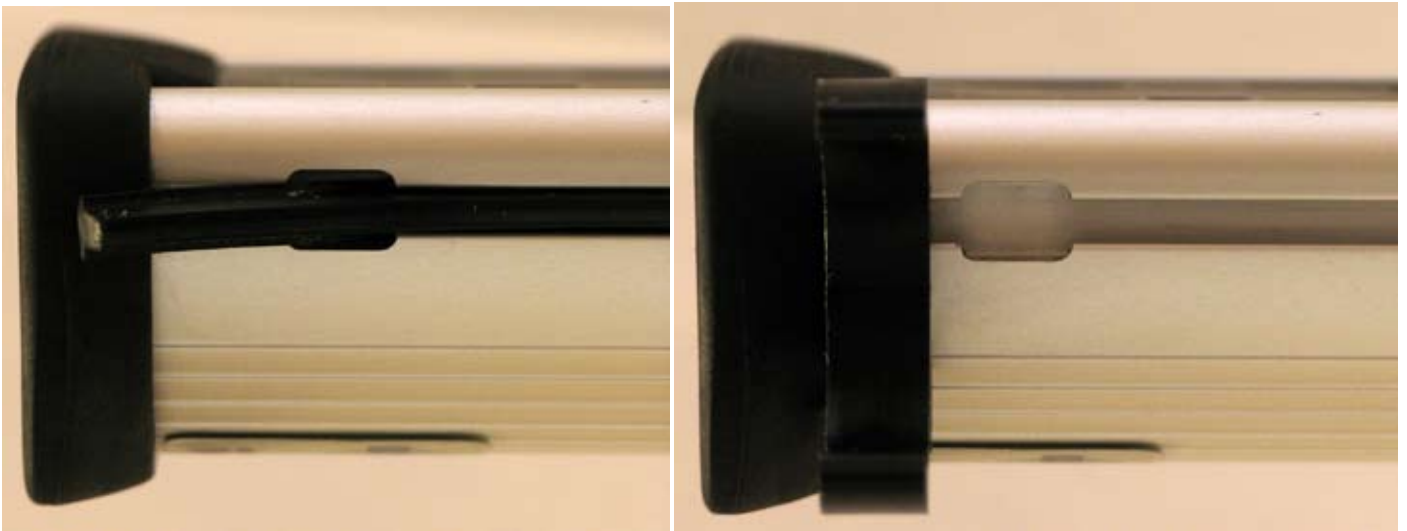

Remove the rubber strip by just pull it out. When you have removed the strip put in the appropriate holders and slide them to the wanted positions.



Now you can attach the probe. (Picture shows SWA 10 with holder)

Starting

The Swema 3000 is a multi-purpose instrument for measuring air velocities, air flows, relative humidity, temperatures and differential pressure. Swema3000, 3000d, 3000md: d means density compensated with inbuilt barometer and thermocouple type K connector. m means inbuilt manometer.

Swema 3000 has individually calibrated, replaceable probes.

As soon as you turn on the instrument with a probe connected, measurement values are displayed. **It's important to turn off**

Swema 3000 before you connect or disconnect a probe. For Swema 3000md toggle between the inbuilt manometer and external probe by using the EXT / INT button.

In addition Swema 3000 will calculate and help you work correctly when using any of the modes included in the Swema 3000. By pressing Enter the measurement mode will start.



Connectors on Swema 3000, 3000d and md. 3000md also has TC connector.

When Swema 3000 is turned on some information about the instrument is displayed under a couple of seconds. Information showed is what model of Swema 3000 it's, wich software version it has and the battery power (under 2.0V the instrument will turn off). If you have a probe connected you will also see what kind of probe it's, next calibration date and serial number of the probe (next calibration date and serial number is not showed for relative humidity probes). If you would like to see this information for more than a couple of seconds hold down the ON/OFF button during turn on, the information is showed until you release the button.

There are some general modes to use with any probe: AP (not SWA03), AS, LOG and LOGP. We suggest to **start to learn the AP and LOG modes.**

For **ventilation** measurements there are some special modes: APF, DPF, AF, BP, ASF and CO. **Start by using APF(SWA31/07/10), DPF (SWA10/07) and BP, AF (SwemaFlow 125/2000/65)**

Swema 3000 can store measurement results in the memory. Measurement notes and logs can easily be transferred to a PC using the program SwemaTerminal.

If you have replaced a probe or connected it for the first time, the instrument always selects the mode which is standard for the connected probe. In addition, the Swema 3000 reads in the calibration and only makes available the modes which are relevant to that particular type of probe. If you switch off the instrument and turn it on again, you will return to the mode you were using. It also remembers what time constant and number of decimal used. Swema 3000 remembers information for the two last probe used plus the inbuilt manometer of Swema 3000md.

At delivery the instrument is set to use k_2 -factors that is reducing the duct surface when calculating flow in APF-mode.

Menu-keys (Page 3)

The lowest part of the display is divided into 3 squares and directly under these squares there are 3 Menu-keys. The buttons functions varies wich is described in the 3 squares above.

Change settings and move around in the Menu

Use the UP/DOWN-arrow key to move between the different lines in the Menu. If you want to change something press ENTER, RIGHT-arrow key or SET (Menu-key to the right). Use UP/DOWN-arrows to choose between the different options you have. If you want to go back to default settings press DEF (Menu-key in the middle) when it's showed. When you are finished with your changes press ENTER, LEFT-arrow key or EXIT (Menu-key to the left). To go back to measuring mode press EXIT.

PC programs

A program, SwemaUSB, for transferring data via USB is included on the CD with this manual. SwemaUSB can also be downloaded on www.swema.com. SwemaUSB is used for updating the Swema 3000, contact Swema. 230V adapter, connects to USB.port. (Part.no. 764.610). RS232-cable for Com-port. (Part.no. 759.030)

The PC-Program SwemaTerminal is free and can be downloaded from www.swema.se.

The PC-program SwemaMultipoint (Part.no. 763.710)

The Swema Multipoint can be used to log data of the two variables showed on the LCD of the Swema 3000. Swema MultiPoint can monitor and log up to 8 Swema 3000 and present it in a live graph.

Swema Multipoint can also be used to create the PPD, PMV and Draught index according to ISO 7730.

For ISO 7730, three Swema 3000, one SWA 03, one HygroClip S and one black globe thermometer are needed.

SwemaMultipoint can only be used with Com-ports. To install more Com-ports on the PC an USB-adpater (driver is included) with 8 Com-ports is available (Part. no. 763.700).

The adapter is connected to a USB-port on the PC. The adapter has 8 9 pole d-sub connectors.

The PC-cable (Part no. 759.030) connects the Swema 3000 to the USB-adapter.

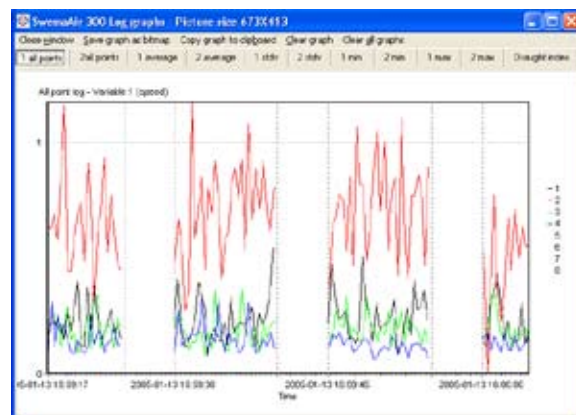
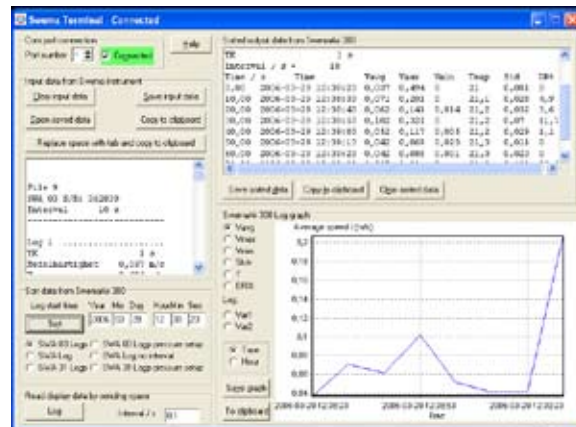

The different probes for Swema 3000

Hot Wire Anemometers

SWA 31 or SWA 31E. Ø 8...10mm, 66 cm long,

SWA 31E extendable up to 116 cm.

0...10 m/s (option 10...30 m/s) and temperature -20...80°C.

Possible measuring modes: AP, APF, AS, ASF, LOG and LOGP.

Extend the probe to the desired length.

Both holes must be clear for air to pass.

Do not pull the cable to close probe.

Orientation advice: Turn the arrow so that the mark on the bottom part of the telescope stem points in the same direction as the arrow.

The air velocity measurement can be influenced by how the holes are located in the flow. See graph.

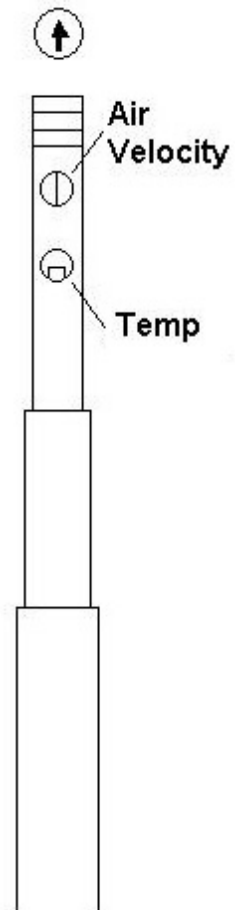
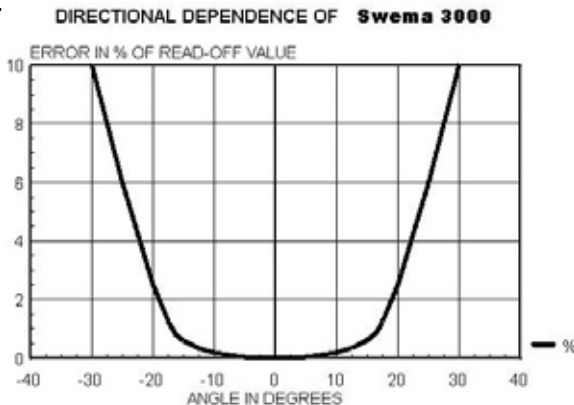

Differential pressure

SWA 07: ± 7000 Pa,

SWA 10 and Swema 3000md: -100...1500Pa.

SWA 10 has a built in valve that automatically zero checks the pressure.

Possible measuring modes: APF (with pito static pipe), DPF (k-factor), AP, AS and LOG.

It is important to show zero pressure at the actual zero pressure.

Otherwise there will be an offset influencing all measurements.

The differential pressure probes SWA 07 and 10 and Swema 3000md can be zeroed to display zero when no pressure is connected. Press the ZERO button when no pressure is connected.

The probe is zeroed for this position. Do not change position when measuring.

Auto Zero ON with SWA 10 or Swema 3000md

SWA 10 and Swema 3000md has an inbuilt zero valve. Auto Zero is set to ON by default.

By the built in valve the zero pressure point is automatically checked every time you take a measurement by pressing "ENTER". When working in this way you never need to calibrate zero manually. Warning: Zeroing may take long time: time constant + 3 sec. If a 4 second time constant is selected it will take 7 seconds to take a measurement.

Auto Zero OFF with SWA 10 or Swema 3000md

With Auto zero Off no zero check is done automatically. The measurement takes shorter time. Due to very stable zero point zero checking is sometimes not needed.

See Menu2 to select Auto Zero ON or OFF

SWA 10 has a small position dependence of $\pm 0,3$ Pa. When you use Auto Zero On and hold the SWA 10 in firm position during zero point checking this error disappears.

The SWA 07 is sensitive to tilting in the longitudinal direction, a 90° tilt producing a change of 4-5 Pa. It is recommended to use the SWA 07 with the magnet holder Art. No. 760.020. SWA 07 is sensitive for temperature shocks. Avoid holding your hand on the SWA 07. Temperature changes of this type will cause zero drift that may take 1-2 minutes to disappear. The temperature compensation works for slow changes. It is possible to log over several hours with minimal zero drift.

Flow captures

SwemaFlow 65: 2...65 l/s,

SwemaFlow 125: 2...125 l/s and

SwemaFlow 2000: 4...900 l/s.

Possible measuring modes: AF, BP (only with SWF 125), AS, LOG and AP.

Draught probe

SWA 03: 0,05...3,0 m/s (omni directional) and 10...34°C.

SWA 03 fulfils ISO 7726.

Possible measuring modes: CO, AS, LOG and LOGP.

Relative humidity and temperature

All probes 0...100%RH

Temperature: HygroClip S -40.....200°C depending on sensor

Possible measuring modes: AP, AS and LOG.

Temperature

Black globe, SWA 53, SWT 315, SWT 215 and with temperature handle SWA 25 also SWT 14, 18, 22, 28, 39, 50, 51 and 53.

-50°C to 280°C depending on probe.

Possible measuring modes: AP, AS and LOG.

CO₂

Connect the Airtest to save and log carbon dioxide values.

Possible measuring modes: AP, AS and LOG.

Radio modem for balancing of ventilation

SwemaTwin transfers measured values on the reference valve from one Swema 3000 to another through radio modem or 40 meter cable. The flow relation between them is displayed, which makes adjustment according to the proportional method an easy task for just one person.

The different modes used in Swema 3000

Choose mode by pressing the MENU1-KEY and move the marker to "Mode" with the UP/DOWN arrow key. Press ENTER, SET or right ARROW KEY and choose mode with the UP/DOWN arrow keys. Confirm your choice with ENTER, EXIT or LEFT arrow key. Set the parameter for the current modes in the same way. Press EXIT to start measuring.

APF (Average Point air Flow) Measured points are taken with ENTER. Average, max, min and measured points are showed on the display. The Swema 3000 calculates the air flow in l/s or m³/h. Enter the diameter, height x width or area direct. If you choose to indicate the height and width or diameter of the duct, the Swema 3000 calculates the effective area = the actual area times the duct factor k_2 in accordance with the recommended measurement methods. The duct factor can be turned off in MENU2. Use the APF mode for measuring the flow in ducts.

DPF (differential Pressure air Flow). Available with a differential pressure probe SWA 10 or SWA 07 or with inbuilt manometer on Swema 3000md. The flow in the measurement of pressure drop across devices is directly obtained in l/s or m³/h.

Insert k-factor, and the Swema 3000 calculates the air flow according to the formula: $q = k \sqrt{\Delta P}$. The specific k-factor is supplied by the manufacturer of (exhaust and supply) ventilation valves.

AF (Average air Flow) Only available with SwemaFlow 2000, 125 and 65. Average Flow is calculated during selectable measuring time.

BP (Back pressure (air flow)) Only available with SwemaFlow 125. This mode is for measurement over supply and exhaust valves to compensate the possible drop in air flow created by the flow capture. BP mode calculates the real flow - the flow not influenced by the flow capture.

AP (Average Point). By using the ENTER button the average is formed from measurements with any probe (except SWA03). Average, max, min and number of measured points are shown.

AS (Auto Sampling). The Swema 3000 continuously collects measured values at the interval set by the Sampling Rate. Use AS mode for example if you want to measure average velocity, max, min, and standard deviation at a point.

ASF (Auto Sampling air Flow). Used with SWA 31 to measure in l/s or m³/h through valves. Sweep over openings in laminar flow hoods/cabinet and over rectangular exhaust and supply ventilation grilles. Select and enter the height x width or area direct into the Swema 3000. ASF does not calculate the area with a k_2 reduction - ASF is not intended for measuring in ducts. There we recommend to use APF instead.

CO (Comfort draught of air). Only available with the omni directional draught probe, SWA 03. CO mode measures average velocity, temperature and standard deviation over a selectable period of time. DR (Draught Rating) is presented in the automatic saved note. The DR indicates the percentage of people that would find the draught unpleasant. The DR is based on experiments conducted at the Technical University in Copenhagen, directed by Professor Fanger. DR is included as a measure of undesirable air movements in the ISO 7730 standard adopted for indoor climates. For a complete ISO7730 measurement use the SwemaMultipoint program.

LOG/LOGP Collects readings over a longer time period. Select interval and time constant for LOG. LOGP is especially developed to be used with SWA 03 draught probe to present the draught rate (ISO 7730) but can be used for other probes aswell. During a "Measure Time" the instrument continuously measures with the selected Time Constant. When the measure time has passed it stops and starts again with a new "Measure Time" at the chosen Protocol interval.

Measuring with APF (Average Point air Flow)

Possible probes are: SWA 31, SWA 31E or SWA 07 or SWA 10 with pito static pipe or Swema 3000md.

Use the APF mode for measuring the flow in ducts.

Swema 3000 calculates the flow in l/s or m³/h by multiplying the air velocity with the duct area.

Reduction of Flow When selecting a circular or rectangular duct it is recommended to reduce the flow by a k_2 -factor. (According to "Methods for measuring air flow in ventilation systems") The air velocity is reduced close to the walls of the duct because of friction. Set the k_2 -factor to ON in the Settings for automatic compensation. Air Flow=Velocity x k_2 x area. To use a non reduced area set the k_2 to OFF, see settings.

When a differential pressure probe is connected the Swema 3000 calculates the air velocity with the formula:

$$\text{Velocity} = \sqrt{2 \Delta P / \rho}$$

ΔP = dynamic pressure =total pressure - static pressure (Pa)
 ρ = density of air = $1,293 \times (B \times 273)/(1013 \times (273 + t))$ (kg/m³)
 B = barometric pressure (calculated standard value 1013hPa)
 t = Air temperature °C (calculated standard value 20°C)
 (With Swema 3000d or md with Thermocople, the measured B and t are used in the formula.)

Connect the air velocity probe or pressure probe with pito static pipe and press ON. Swema 3000 is in measuring mode. Press the MENU1-KEY and move the marker to "Mode" and change to APF.

Set the PARAMETERS for measuring mode APF:

Time Constant, update of the displayed value (for more information see Time Constant under Technical Data).

Ø set the diameter of the duct you want to measure. Move the marker to "Ø" with the up/down arrow key. Press ENTER or SET and choose the diameter. Choose among standard diameters with the up / down arrow key. To set the diameter to your choice press EDIT and change with the arrow keys. Press EXIT or ENTER to confirm.

H x W set the height and width of the duct you want to measure. Move the marker to "H x W" with the up/down arrow key. Press ENTER or SET and choose height with the arrow keys. Press ENTER or OK and set the width with the arrow keys. Press ENTER or EXIT to confirm.

Area set the area of the duct. (k_2 reduction will not be made)

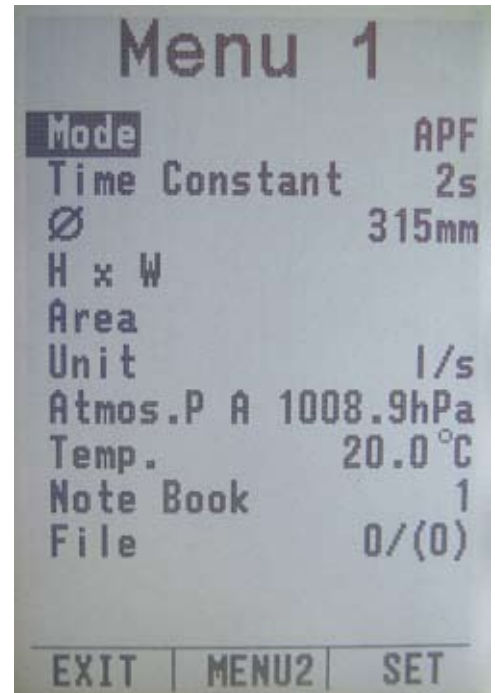

Choose mode by pressing the MENU1-KEY and move the marker to "Mode" with the up/down arrow key. Press ENTER or SET and choose mode with the up/down arrow key. Confirm with EXIT or ENTER. Set the parameters and press EXIT to start measuring.



When measuring, collect values with the ENTER button. When values are collected the display will show average-, maximum-, minimum-values and number of measurements.

Recommended measuring points for circular and rectangular ducts

From "Methods for measuring air flow in ventilation systems", by the Nordic Ventilation Group and the Building Research Council, 1998, ISBN 91-540-5827-9. For $D \leq 400$, k_2 values are from NBI report Nordtest-proj. No. 1463-99.

Circular cross-section: *)

$D \leq 160 \text{ mm} \rightarrow k_2 = 0,92$ (SWA 31), 0,89 (Pito Static Pipe)

$160 < D \leq 400 \text{ mm} \rightarrow k_2 = 0,96$ (SWA31), 0,95 (Pito Static Pipe)

$400 < D \leq 1250 \text{ mm} \rightarrow k = 0,98$

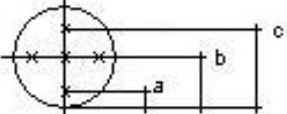
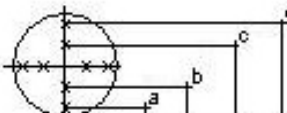
Nominal diam = D [mm]	Measuring plan	a	b	c	d
100 } 125 } ¹⁾ 160 }	 $b=0.71D$ $a=0.29D$	29 36 46	71 89 114		
200 250 315 400	 $c=0.9D$ $b=0.5D$ $a=0.1D$	20 25 32 40	100 125 160 200	180 225 283 360	
500 630 800 1000 1250	 $d=0.957D$ $c=0.71D$ $b=0.29D$ $a=0.043D$	22 27 34 43 54	145 185 230 290 360	355 445 570 710 890	478 603 766 957 1196

¹⁾ The diameter of Prandtl tube should not exceed 1/30 of the diameter of the duct.

In the case of duct dimensions < 200 mm, a Prandtl tube with a diameter of 3-4 mm should be used..

Rectangular cross-section:

*) Vertical duct ($L_1 > L_2$) $\Rightarrow k_2 = 0.94$
Horizontal duct ($L_1 < L_2$) $\Rightarrow k_2 = 0.98$
Square cross-section $\Rightarrow k_2 = 0.96$

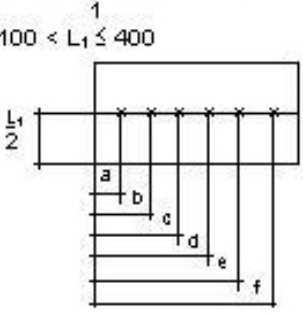
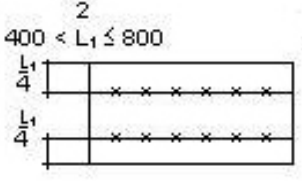
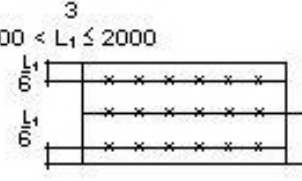
		According to new duct standard SIS 82 72 04												
Two dimension ranges for L_2 :		I $200 < L_2 \leq 300$ II $400 < L_2 \leq 2000$												
For range I:		$a = 0.08L_2, b = 0.43L_2, c = 0.57L_2, d = 0.92L_2$												
For range II:		$a = 0.060L_2, b = 0.235L_2, c = 0.430L_2, d = 0.570L_2, e = 0.765L_2, f = 0.940L_2$												
Three cases for L_1 (height):														
1 $100 < L_1 \leq 400$		2 $400 < L_1 \leq 800$				3 $800 < L_1 \leq 2000$								
														
		The following location of measuring points is obtained for measurement cases 1, 2 and 3 dependent on L_2 (width).												
L_2	150	200	250	300	400	500	600	800	1000	1200	1400	1600	1800	2000
a	13	16	20	25	25	30	35	50	60	70	85	95	110	120
b	65	85	110	130	95	120	140	190	235	280	330	375	420	470
c	85	115	140	170	170	215	260	345	430	515	600	690	775	860
d	137	184	230	275	230	285	340	455	570	685	800	910	1025	1140
e	—	—	—	—	305	380	460	610	765	920	1070	1225	1380	1530
f	—	—	—	—	380	470	565	750	940	1130	1314	1505	1690	1880

When measuring in a duct it is necessary to do this where the duct is straight. According to "Methods for measuring air flow in ventilation systems" the straight length before and after the measurement position must at least be:

	Round ducts	Rectangular ducts
Before measuring position	$a \geq 5 \times D$	$a \geq 6 \times Dh$
After measuring position	$a \geq 2 \times D$	$a \geq 2 \times Dh$

Dh=Hydraulic diameter (Diameter or corner to corner for rectangular ducts)

Unit choose the unit you want to measure with l/s, m³/h or CFM.

Atmospheric pressure see Menu1

Temperature see Menu1

See **Note Book, Log Book and File**

Auto zero (For differential pressure)

See Menu2, The different probes for Swema 3000.

To manually zeroing the pressure sensor - press the Zero button.

When all parameters are set press the EXIT-button to get back to measuring position. Swema 3000 will show selected Ø, Height x Width or Area.

Collect values with the ENTER-button. When values are collected the display will show average-, maximum-, minimum-values and number of measurements. When all values are collected you can choose if you want to clear or save your measurement.

To clear press the CLEAR-button and to save press the SAVE-button. If you press the SAVE-button the instrument saves your measurement at the first free memory place in the note book memory. The instrument also give a short signal and displays the memory place for a few seconds. See Note Book.

Please Note! If Swema 3000 with an inbuilt barometer and thermoelement is used. The displayed Avg, Max and Min values are then calculated by the barometric pressure and temperature value at the different measuring points. When saving the measurement a mean value of the barometric pressure and temperature will be saved. The mean values will then be used to calculate the saved values in the Note book.



When all values are collected you can choose if you want to clear or save your measurement.

Measuring with DPF (Differential Pressure air Flow)

Possible probes with DPF are: SWA 07 or SWA 10 and Swema 3000md.

See Differential pressure in the section The different probes for Swema 3000.

The flow in the measurement of pressure drop across valves is directly obtained in l/s or m³/h.

$$q = k \sqrt{\Delta P}$$

The k-factor is supplied by the manufacturer of the valve.

It should be defined so that result comes out in liter/s.

If you would like the result in m³/h then still use the k-factor that is valid for liter/s calculation and the Swema 3000 will calculate to m³/h.

Set the PARAMETERS for measuring mode DPF:

Time Constant, update of the displayed value (for more information see Time Constant under Technical Data).

K-factor In Swema 3000 you have a memory for 20 K-factors. It is useful when there are different k-factors for different positions of the valve. Move the marker to "K-factor" with the UP/DOWN arrow key. Press ENTER or SET and choose with the UP/DOWN arrow keys which K-factor memory place (1-20) you want to set. Press EDIT and edit your K-factor with the arrow keys. Confirm your choice by pressing ENTER or EXIT two times.

Unit choose the unit you want to measure with l/s, m³/h or CFM.

Atmospheric pressure see Menu1

Temperature see Menu1

Auto zero See Menu2, The different probes for Swema 3000. To manually zeroing the pressure sensor - press the Zero button.

See Note Book, Log Book and File

When all parameters are set press the EXIT-button to get back to measuring position. Swema 3000 will show selected K-factor the pressure and the air flow. Collect values with the ENTER-button. When values are collected the display will show average-, maximum-, minimum-values and number of measurements. When all values are collected you can choose if you want to clear or save your measurement.

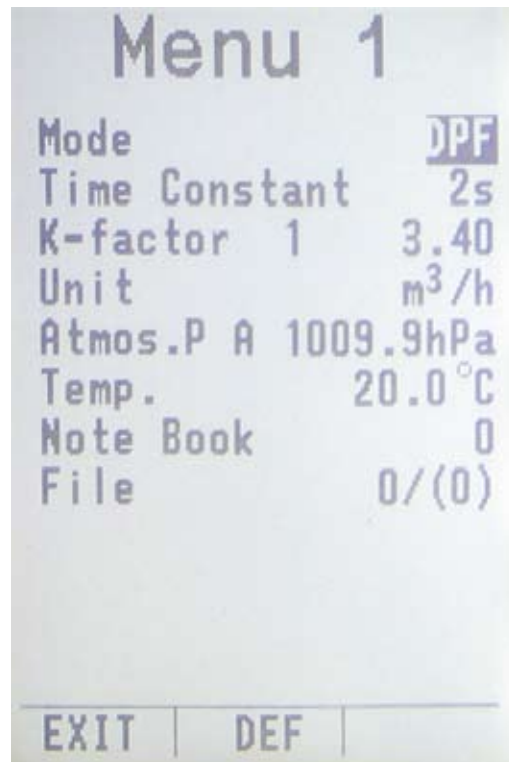

Choose mode by pressing the MENU1-KEY and move the marker to "Mode" with the up/down arrow key. Press ENTER or SET and choose mode with the up/down arrow key. Confirm with EXIT or the ENTER. Set the parameters and press EXIT to start measuring.



When measuring, collect values with the enter button. When values are collected the display will show average-, maximum-, minimum-values and number of measurements.

To clear press the CLEAR-button and to save press the SAVE-button. If you press the SAVE-button the instrument saves your measurement at the first free memory place in the note book memory. The instrument also give a short signal and displays the memory place for a few seconds.

Please Note! If Swema 3000 with an inbuilt barometer and thermoelement is used. The displayed Avg, Max and Min values are then calculated by the barometric pressure and temperature value at the different measuring points. When saving the measurement a mean value of the barometric pressure and temperature will be saved. The mean values will then be used to calculate the saved values in the Note book.



When all values are collected you can choose if you want to clear or save your measurement.

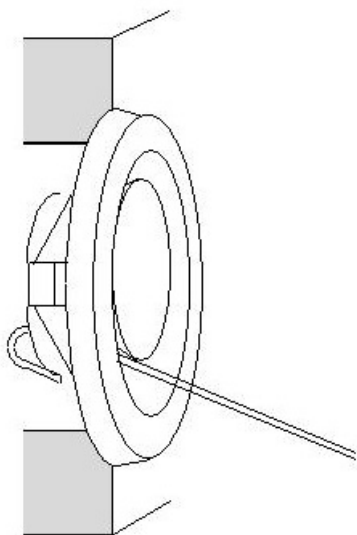

Use the k-factor to calculate the air flow. Certain suppliers calculate the correction factor using the formula:

$$q = \sqrt{I_k \Delta P}$$

In such case you must enter: $k = \sqrt{I_k}$ in Swema 3000.

If the supplier has not specified a k-factor, You calculate it easily if you have a pressure-drop diagram. Proceed as follows: $q = k \sqrt{\Delta P} \rightarrow k = q / \sqrt{\Delta P}$.

Now go into the diagram for example:

$$\Delta P = 100 \text{ Pa} \rightarrow \sqrt{\Delta P} = \sqrt{100} = 10$$

for $\varnothing 100$: 100Pa correspond to 50 l/s

$$\text{Use the calculation for } k: k = 50/10 \rightarrow 5,0$$

So the k factor in this case was 5,0. Set this in Swema 3000 to obtain the flow in l/s, m3/h or CFM.

If the diagram does not extend to 100 Pa, select for example 25 Pa
($\sqrt{25} = 5$)

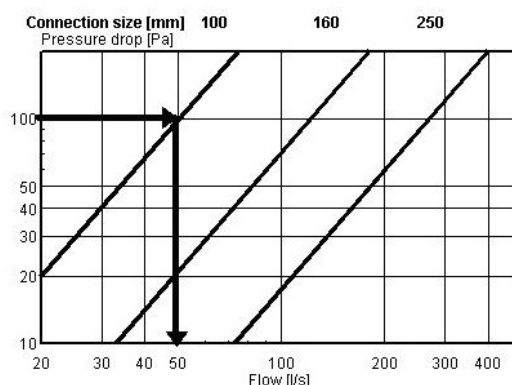

Measuring with AF (Average Flow)

Possible for flow captures: SwemaFlow 65, SwemaFlow 125 or SwemaFlow 2000.

If you have the SwemaFlow 125 Swema recommends BP mode. Average Flow is calculated during selectable measuring time and presented on the display (time constant + selected measuring time). Connect the flow capture hood and press ON. After a few seconds Swema 3000 is in measuring position. Choose mode by pressing the MENU1-KEY and move the marker to "Mode" with the up/down arrow key. Press ENTER or SET and choose mode with the up/down arrow key. Confirm with EXIT or the ENTER.

Set the PARAMETERS for measuring mode AF:

Start delay is the waiting time before measuring, to stabilising the flow in the flow capture.

Sampling Time Make an average value during this time.

Flow Factor It is possible to multiply the flow with a flow factor. Flow factor=1.00 will not alter the flow. Warning: Changing to anything else will alter the reading from calibrated value. This can be used to compensate for example for leakage.

Unit choose the unit you want to measure with l/s, m³/h or CFM.

Atmospheric pressure see Menu1

Temperature see Menu1

See **Note Book, Log Book and File**

When all parameters are set, press EXIT to start measuring.

Start measuring with the ENTER-button (or button on SwemaFlow 125/2000). Swema 3000 will collect values and calculate the minimum, maximum and average air flow and standard deviation during the selected Sampling Time. When all values are collected you can choose if you want to clear or save your measurement. To clear press the CLEAR-button and to save press the SAVE-button. If you press the SAVE-button (or long press on button on SwemaFlow 125/2000) the instrument saves your measurement at the first free memory place in the Note Book memory.

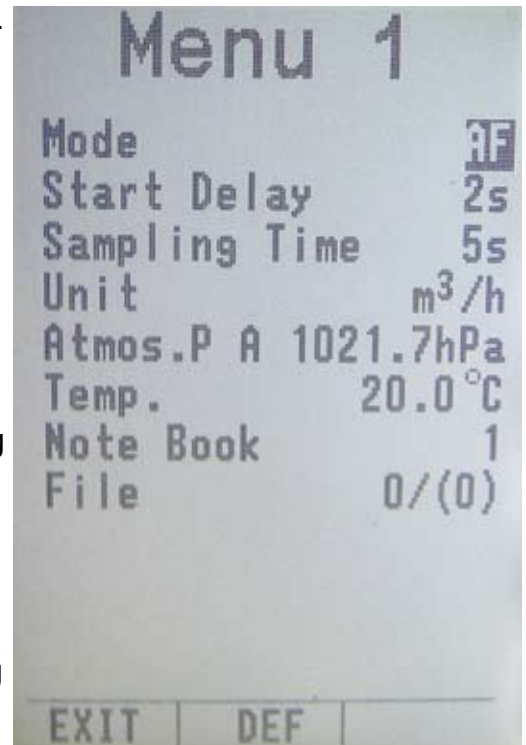

Choose mode by pressing the MENU1-KEY and move the marker to "Mode" with the up/down arrow key. Press ENTER or SET and choose mode with the up/down arrow key. Confirm with EXIT or the ENTER.

Set the parameters and press EXIT to start measuring.



When measuring, Start the measuring with the enter button. Then you can choose if you want to clear or save your measurement.

Measuring with BP (Back Pressure)

Possible probe with BP is: SwemaFlow 125

When measuring with any Flow capture the flow may be influenced by the flow capture itself. The flow may be throttled. This can be corrected by using the Back Pressure mode. By measuring two times with SwemaFlow 125, with and without an extra throttle ring. Swema 3000 calculates the flow that reflects the true flow, with no capture interference. In the same way as AF mode the BP mode makes an average measurement over time.

Connect the SwemaFlow 125 and press ON. After a few seconds Swema 3000 is in measuring position.

Set the PARAMETERS for measuring mode BP:

Start delay is the waiting time before measuring, to stabilising the flow in the flow capture.

Sampling Time Make an average value during this time.

Unit choose the unit you want to measure with l/s, m³/h or CFM.

Atmospheric pressure see Menu1

Temperature see Menu1

See **Note Book, Log Book and File**

When all parameters are set press the EXIT-button to get back to measuring mode.

When measuring with the throttle ring, the ring shall always be placed after the hot wires in the sense of flow direction. The display will show PO 1. Place the throttle ring on the measuring unit and place the capture over the valve and press enter.

When "Point 1" is measured you hear a beep and the display shows PO 2. Within one minute you must measure "Point 2" without the throttle ring otherwise the instruments returns to "Point 1". Remove the throttle ring and place the capture over the valve once more and press enter. It is also possible to take the first measure without the throttle ring and the second with the throttle ring.

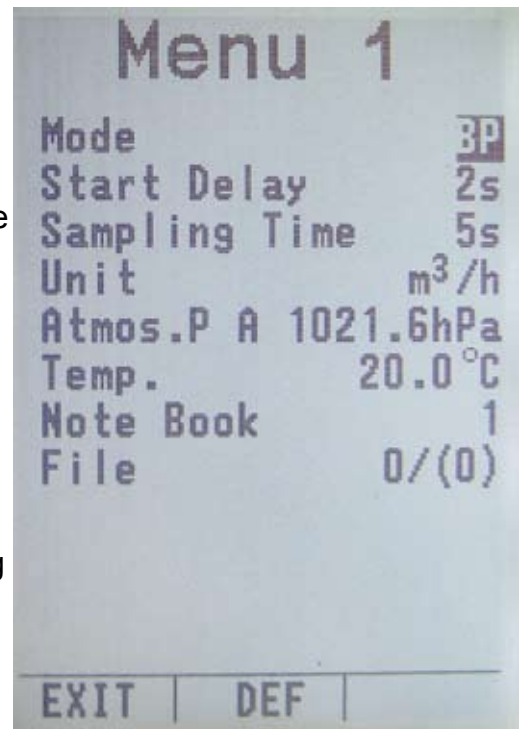

Choose mode by pressing the MENU1-KEY and move the marker to "Mode" with the up/down arrow key. Press ENTER or SET and choose mode with the up/down arrow key. Confirm with EXIT or the ENTER.. Set the parameters and press Exit to start measuring.

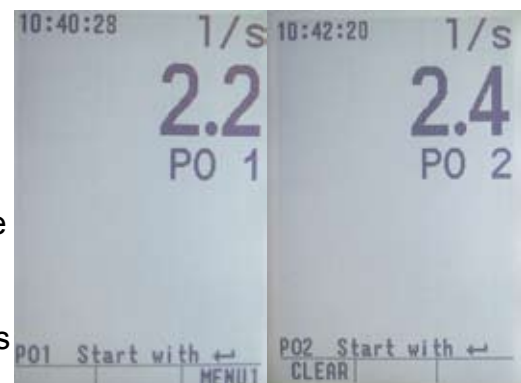

The display will show PO 1. Start with the throttle ring on and press Enter to collect the first value, When ready with the first value the display will show PO 2. Remove the throttle ring and collect the second value by pressing Enter. The button on SwemaFlow 125 can also be used as a Enter-button. A long press will save a measurement.

The display will now show the true value and measuring point 1 & 2. If the measured value are flashing there is to big difference between point 1 & 2 and the result is not reliable.

You can now choose if you want to clear or save your measurement.

To clear press the CLEAR-button and to save press the SAVE-button. If you press the SAVE-button the instrument save your measurement at the first free memory place in the note book memory. The instrument also give a short signal and display the memory place for a few seconds.



After PO 2 is measured the display will calculate the true value and show it on the display. The display will also show point 1 & 2. Max is without the ring and Min is with the ring. Then you can choose if you want to clear or save your measurement.

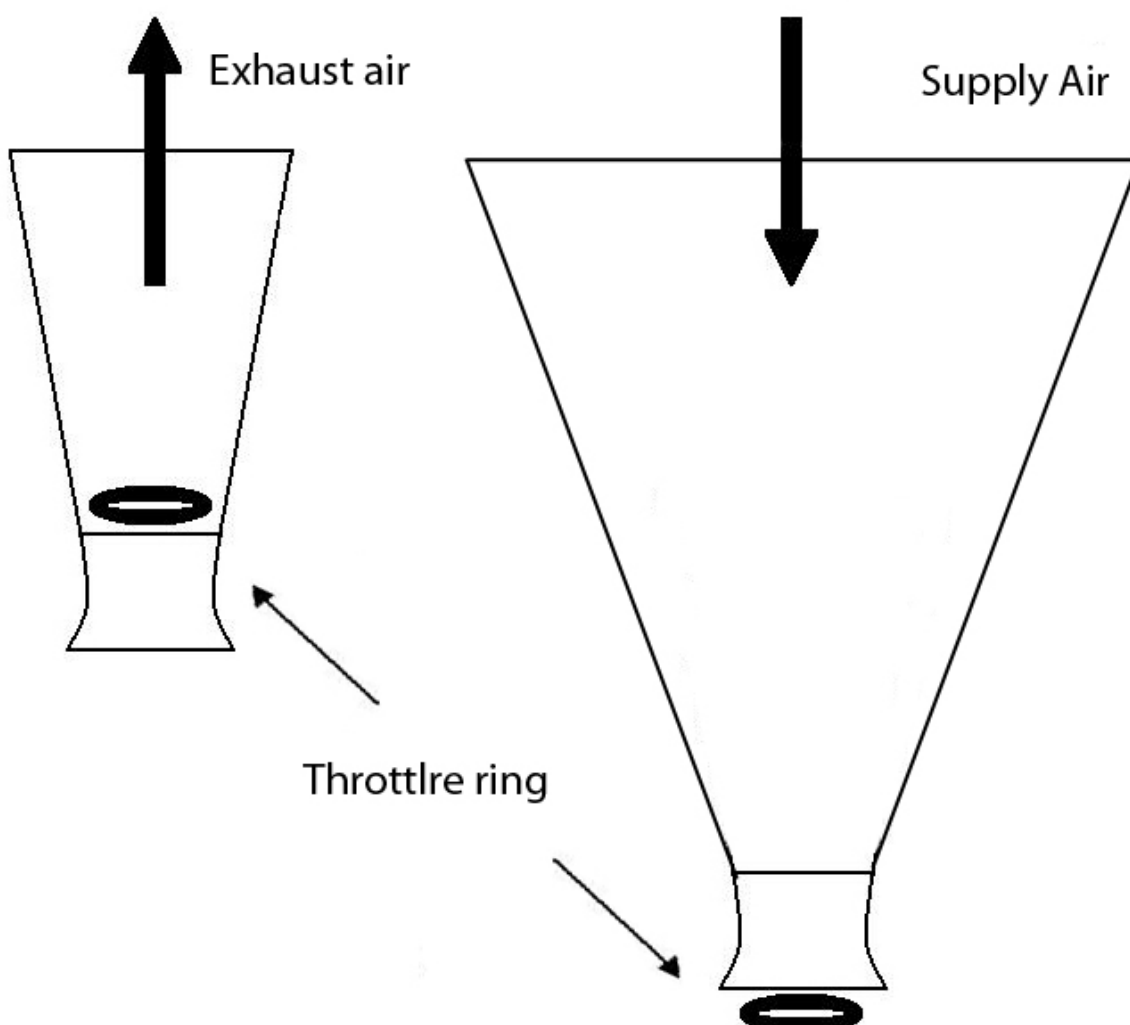

Measuring with AP (Average Point)

Possible with all probes except SWA 03.

Measures the actual values of the connected probe. Calculates average and display Max and Min.

Set the PARAMETERS for measuring mode AP:

Time constant, update of the displayed value (for more information see Time Constant under Technical Data).

Unit Only for SwemaFlow: Choose the unit you want to measure with l/s, m³/h or CFM. See settings for more information.

Atmospheric pressure see Menu1

Temperature see Menu1

See **Note Book, Log Book and File**

When all parameters are set press the EXIT-button to get back to measuring mode.

Collect values with the ENTER-button. When values are collected the display will show average-, maximum-, minimum-values and number of measurements. For Relative humidity probes Swema 3000 displays the dew point and mixing ratio (g water / kg dry air)

When all values are collected you can choose if you want to clear or save your measurement.

To clear press the CLEAR-button and to save press the SAVE-button. If you press the SAVE-button the instrument save your measurement at the first free memory place in the note book memory. The instrument also gives a short signal and displays the memory place for a few seconds.

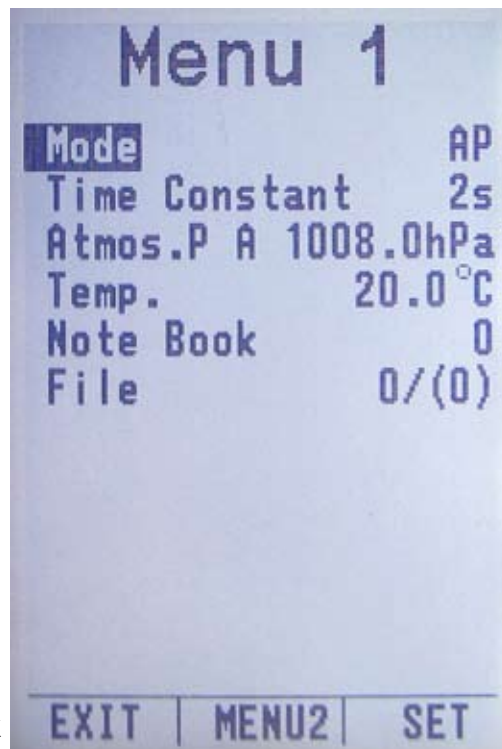

Choose mode by pressing the MENU1-KEY and move the marker to "Mode" with the up/down arrow key. Press ENTER or SET and choose mode with the up/down arrow key. Confirm your choice with ENTER or EXIT. Set the parameters and press EXIT to start measuring.

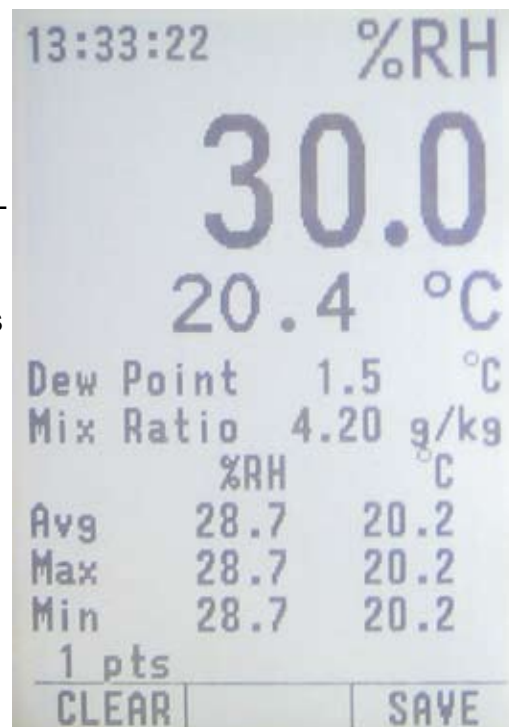

When measuring, collect values with the enter button. When values are collected the display will show average-, maximum-, minimum-values and number of measurements.

Measuring with AS (Auto Sampling)

Possible with all probes

AS continuously sample values direct after each other. AS does not save all values. Instead it calculates the average, max, min and standard deviation of the sampled values.

Connect any probe and press ON. After a few seconds Swema 3000 is in measuring mode.

Set the PARAMETERS for measuring mode AS:

Sampling Rate is the time Swema 3000 uses to sample measured values, make an average and display the value. Swema 3000 uses a floating mean value, i.e. for example if a "Sampling rate" of 30s is used, Swema 3000 sample a value 2 times/second during 30 seconds (60 values) and shows an average value of them. After 30 seconds the first value will be replaced by a new and a new average will be calculated and shown on the display etc. Swema 3000 always collect a value 2 times/second with a "Sample rate" of 0,5s or higher. If a lower sample rate than 0.5s is used Swema 3000 will sample and display the value at the same rate the chosen "Sample rate".

Unit Only for SwemaFlow: Choose the unit you want to measure with l/s, m³/h or CFM. .

Atmospheric pressure see Menu1

Temperature see Menu1

See **Note Book, Log Book and File**

When all parameters are set press the EXIT-button to get back to measuring mode.

Start and stop measuring with the ENTER-button. Swema 3000 will collect values and calculate the average. It will also calculate standard deviation, number of measuring points and maximum and minimum.

When using a differential pressure AS will calculate the air velocity, assuming a pito static pipe is connected to the differential pressure probe. When all values are collected you can choose if you want to clear or save your measurements.

To clear press the CLEAR-button and to save press the SAVE-button. If you press the SAVE-button the instrument saves the measurements at the first free memory place in the note book memory. The instrument also gives a short signal and displays the memory place for a few seconds.

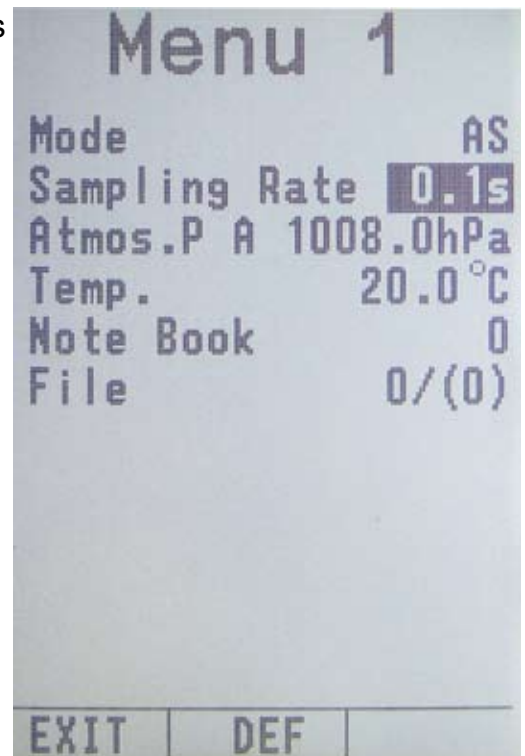

Choose mode by pressing the MENU1-KEY and move the marker to "Mode" with the up/down arrow key. Press ENTER or SET and choose mode with the up/down arrow key. Confirm your choice with ENTER or EXIT. Set the parameters and press Exit to start measuring.



Start and stop the sampling by pressing Enter. When the sampling are done you can choose if you want to clear or save your measurement.

Measuring with ASF (Auto Sampling Flow)

Possible probes with ASF are: SWA 31 or SWA 31E.

Same as AS, but the Swema 3000 calculates the flow in l/s or m³/h. In ASF mode the area is not reduced by a k₂-factor. Use ASF mode for example to measure the flow and air velocity in fume hoods and over grilles. ASF is not intended for measuring in ducts and diameters and duct coefficient are therefore omitted.

Connect the air velocity probe and press ON. After a few seconds Swema 3000 is in measuring mode.

Set the PARAMETERS for measuring mode ASF:

Sampling Rate is the time Swema 3000 uses to sample measured values, make an average and display the value. Swema 3000 uses a floating mean value, i.e. for example if a "Sampling rate" of 30s is used, Swema 3000 sample a value 2 times/second during 30 seconds (60 values) and shows an average value of them. After 30 seconds the first value will be replaced by a new and a new average will be calculated and shown on the display etc. Swema 3000 always collect a value 2 times/second with a "Sample rate" of 0,5s or higher. If a lower sample rate than 0.5s is used Swema 3000 will sample and display the value at the same rate the chosen "Sample rate".

H x W set the height and width of the duct you want to measure.

Area set the area of the duct.

Unit choose the unit you want to measure with l/s or m³/h.

Atmospheric pressure see Menu1

Temperature see Menu1

See **Note Book, Log Book and File**

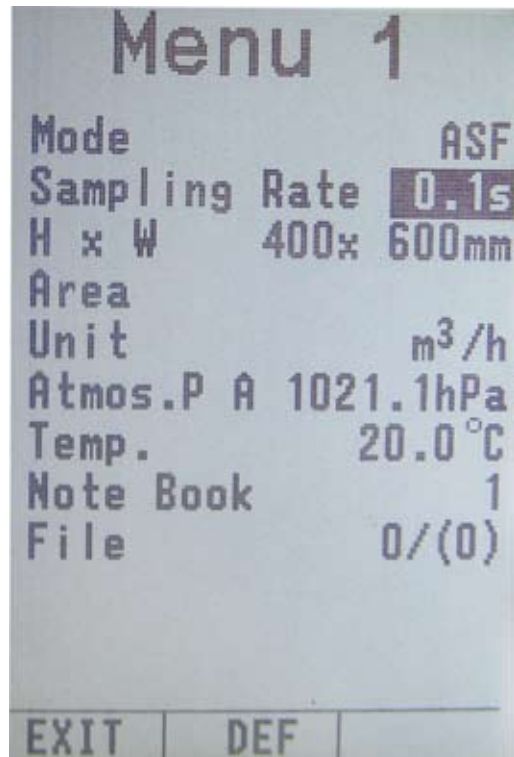

Choose mode by pressing the MENU1-KEY and move the marker to "Mode" with the up/down arrow key. Press ENTER or SET and choose mode with the up/down arrow key. Confirm your choice with ENTER or EXIT. Set the parameters and press Exit to start measuring.



Start and stop the auto sampling flow by pressing Enter.

Start and stop measuring with the ENTER-button. Swema 3000 will collect values and calculate the average air flow and temperature. It will also calculate standard deviation, number of measuring points and maximum and minimum air flow. When all values are collected you can choose if you want to clear or save your measurement.

To clear press the CLEAR-button and to save press the SAVE-button. If you press the SAVE-button the instrument saves your measurement at the first free memory place in the note book memory. The instrument also gives a short signal and displays the memory place for a few seconds.



When the sampling are done you can choose if you want to clear or save your measurement.

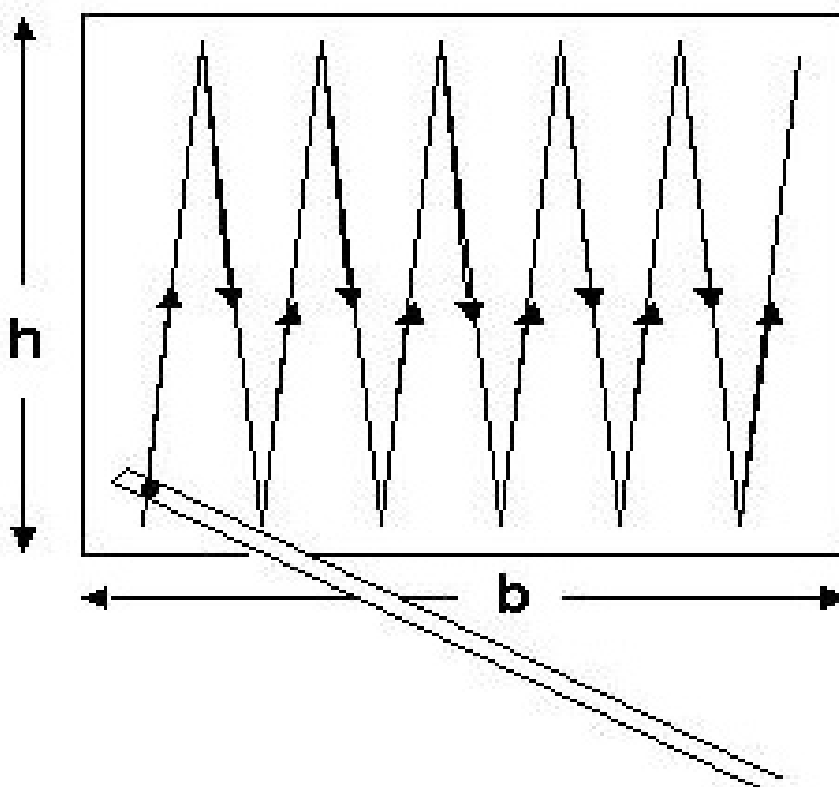

Measure the total flow by gently sweeping the probe across the surface. Set the time constant as low as possible.

Measuring with CO (Comfort)

Possible probe with CO is: SWA 03.

CO mode measures average velocity and temperature and standard deviation. In the note book you can also view DR (Draught Rating). DR indicates as a percentage how many people find the draught unpleasant. DR is included as a measure of undesirable air movements in the ISO 7730 standard adopted for indoor climates. DR is based on experiments conducted at the Technical University in Copenhagen, directed by Professor Fanger.

Connect the draught probe and press ON. After a few seconds Swema 3000 is in measuring mode.

Set the PARAMETERS for measuring mode CO:

Display Time The display can be updated with an interval of 0,5, 0,25 or 0,1 seconds.

Measure time Over the Measure Time the measurements are sampled. Each measurement is sample with the internal sampling rate during 0,1s. From these measurements the average, max, min, standard deviation and draught rating is calculated. ISO 7730 suggests 3 minutes as Measure Time.

Atmospheric pressure see Menu1

Temperature see Menu1

See **Note Book, Log Book and File**

When all parameters are set press the EXIT-button to get back to measuring mode.

Start the draught measurement with the ENTER-button. Swema 3000 will take measurments during the selected measuring time and will automatically save to the first free memory place in the note book. The instrument also gives a short signal and displays the memory place for a few seconds.

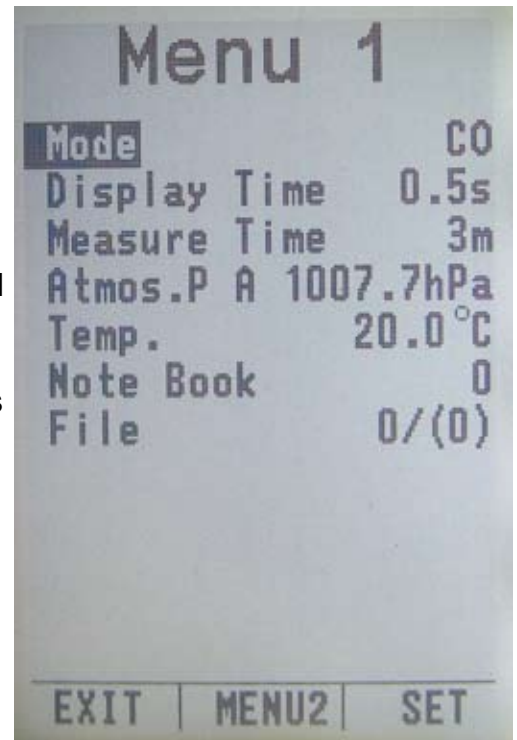

Choose mode by pressing the MENU1-KEY and move the marker to "Mode" with the up/down arrow key. Press ENTER or SET and choose mode with the up/down arrow key. Confirm your choice with ENTER or EXIT. Set the parameters and press EXIT to start measuring.



The measurement is automatically saved in the note book. To see the draft rate, press the MENU-key and move the marker to Note Book and press enter.

Measuring with LOG (Logging)

Possible with all probes

Collects readings at user-selectable intervals and time constant. Use LOG mode to measure throughout longer time. (Ex: variations of air flow and pressure throughout 24-hours.). Connect an 230V adapter if you want to log longer time than 12 hours.

Connect any probe and press ON. After a few seconds Swema 3000 is in measuring position.

Set the PARAMETERS for measuring mode LOG:

Time constant, update of the displayed value (for more information see Time Constant under Technical Data).

Interval is the time between when Swema 3000 saves a value, the value saved is the one shown on the display.

Atmospheric pressure see Menu1

Temperature see Menu1

See Note Book, Log Book and File

When all parameters are set press the EXIT-button to get back to measuring position.

Start and stop the log with the ENTER-button. If a Time Constant of 10s or higher is used an information about when the next log point will be is shown on the display.

After the second push on ENTER (or on SAVE) the Swema 3000 will save the collected measurements to the first free memory place in the log book. The instrument also gives a short signal and displays the memory place for a few seconds.

When using a differential pressure probe with LOG an auto zeroing will be made before every log point (Time constant must be 10s or higher and Auto zero in MENU2 must be set ON).

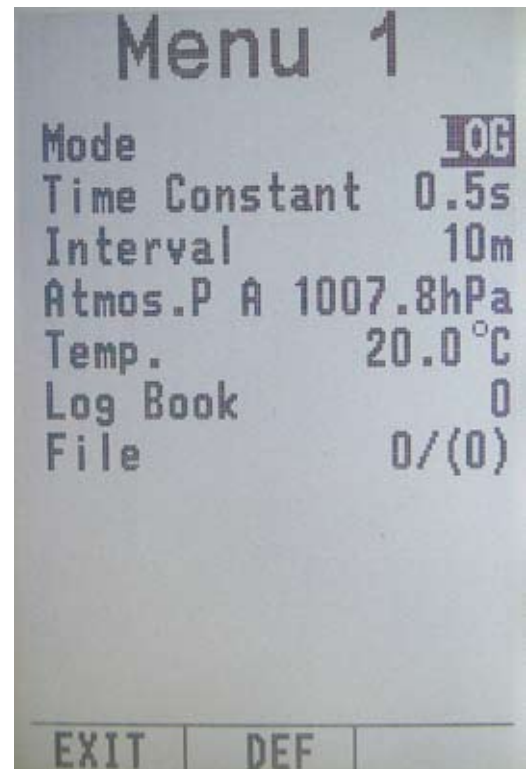

Choose mode by pressing the MENU1-KEY and move the marker to "Mode" with the up/down arrow key. Press ENTER or SET and choose mode with the Up/down arrow key. Confirm your choice with ENTER or EXIT. Set the parameters and press Exit to go to measuring position.



Start and stop the log with the ENTER-button.

Measuring with LOGP (Logging Protocols)

Possible probe with LOGP is: SWA 31, SWA 31E and SWA 03.

LOGP is Log series of measurements presented in protocols (notes) with maximum, minimum, average and the standard deviation. Each protocol (note) represents one measuring serie.

Set the PARAMETERS for measuring mode LOGP:

Time constant, update of the displayed value (for more information see Time Constant under Technical Data).

Measure Time here you select the length of the measuring series. Swema 3000 calculate average, maximum, minimum and standard deviation of the selected "Measure Time".

Log Interval here you select in which interval a measuring serie will start. From the start of one protocol (Measure time) to the start of the next.

atmospheric pressure see Menu1

Temperature see Menu1

See **Note Book, Log Book and File**

When all parameters are set press the EXIT-button to get back to measuring mode.

Start and stop the log with the ENTER-button. Swema 3000 open a new "File" and log series and save them to the first free memory place in the log book in the new "File". The instrument also give a short signal and display the memory place for a few seconds. If you stop the logging before the end of the first serie, no data is saved.

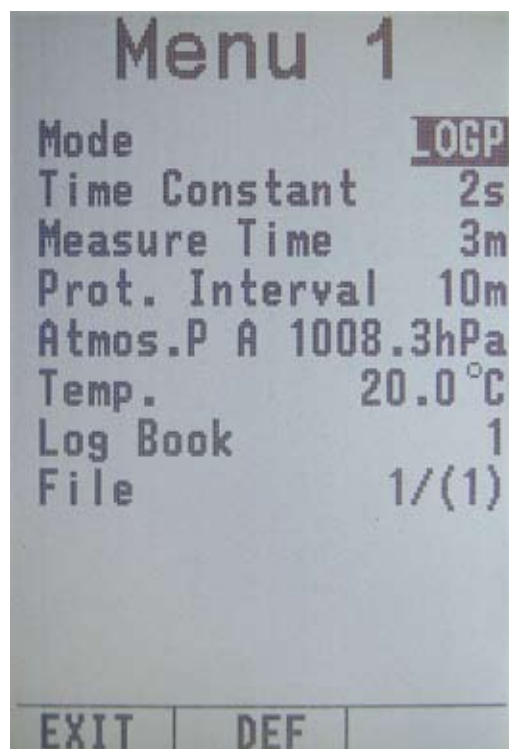

In this example:
Each serie is set to 3 minutes. After one serie is finished another one starts after 7 minutes.

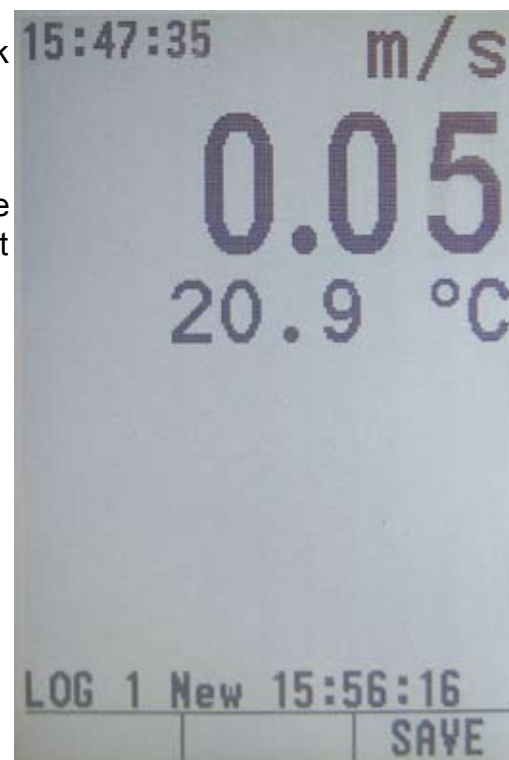

Start and stop the log with the ENTER-button.

Note Book, Log Book and File

To access the Note Book or Log Book press "MENU1" key.

To access "Note Book" select one of the following modes: AP, APF, AS, ASF, DPF or CO.

To access "Log Book" select mode LOG or LOGP.

Note Book / Log Book

To see the Notes (measurements) in the active file, move the marker to "Note Book" or "Log Book" with the UP/DOWN arrow keys. Press Enter, Set or right arrow. Browse between your measurements with the UP/DOWN arrow keys. Connect a PC-cable. To transfer a note or log file to a PC just press Print. A long press on print will transfer the complete log book or note book. For software's see SwemaTerminal and Swema Multipoint. Erase with the ERASE-button. If you erase in "Note Book" you can choose to either erase the Note or the whole File, in "Log Book" you always erase the whole File. Exit with the EXIT-button.

File

To access Log Files select Mode LOG or LOGP

To access Note Files select any other Mode.

Files are used when you want to group your measurements.

The total Air Flow for all Notes in a File can be added when printing out a file. See Add Flow in Settings.

To start a new file, to access measurements in another file, or to erase the last or all files, move the marker to "File" with the UP/DOWN arrow keys.

Select SET, ENTER or right button to enter the File menu.

To start a new file for "Note Book" press ENTER when you are in the File menu. A new File for "Log Book" are created when a new log with LOG or LOGP is made

To erase the last file press Erase. Select OK to Erase the last file. Press All to erase all Files. If you select OK the last file is emptied. All measurements are areased from the last file, but new measurements have to be put in this file. Therefor the display shows "New empty File X". X is the number for the File you just erased. If you erase one more File File X will be erased and File X-1 will be emptied.

Browse between your log files with the UP/DOWN arrow keys. When you have selected the file you want to see, press Exit. Now you can see you measurements our log files by going to the "Note Book" or "Log Book" as described above.

To transfer to a PC. Connect a PC-cable. Press Print while you are in the File-menu. A long press will transfer the complete note/log book. See SwemaTerminal.

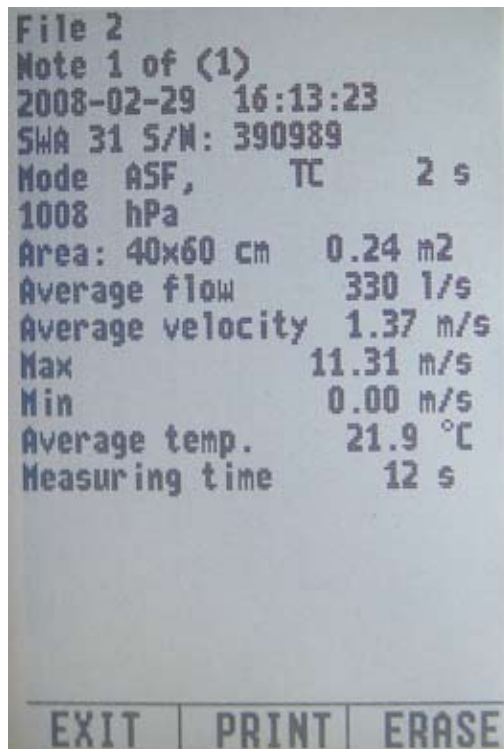

File 2
Note 1 of (1)
2008-02-29 16:13:23
SWA 31 S/N: 390989
Mode ASF, TC 2 s
1008 hPa
Area: 40x60 cm 0.24 m2
Average flow 330 l/s
Average velocity 1.37 m/s
Max 11.31 m/s
Min 0.00 m/s
Average temp. 21.9 °C
Measuring time 12 s

EXIT | PRINT | ERASE

Open your Note or Log files by moving the marker to "Note Book" or "Log Book" with the arrow keys and press Enter.

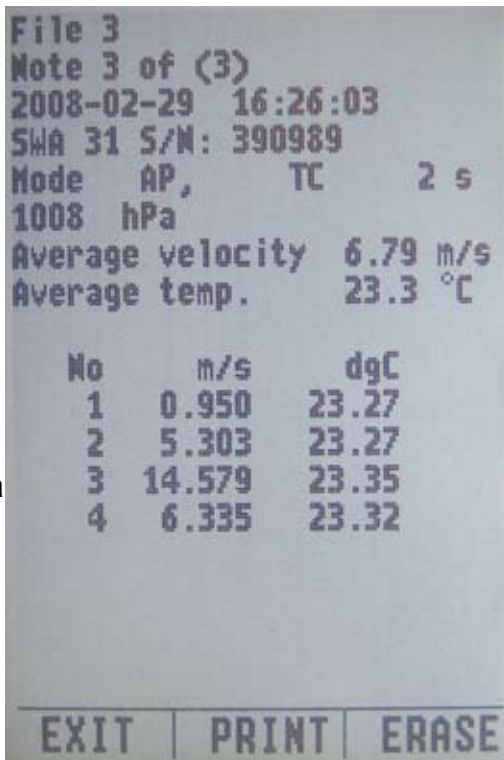

File 3
Note 3 of (3)
2008-02-29 16:26:03
SWA 31 S/N: 390989
Mode AP, TC 2 s
1008 hPa
Average velocity 6.79 m/s
Average temp. 23.3 °C

No	m/s	dgC
1	0.950	23.27
2	5.303	23.27
3	14.579	23.35
4	6.335	23.32

EXIT | PRINT | ERASE

In the Note Book or Log Book:
Alter between your notes with UP/DOWN arrow keys.

This is also how the note will look like on the PC.

Leakage tester for Building

To control the leakage tester automatically a Swema 3000md and a SWA 10 or SWA 07 are needed. The built in differential pressure sensor in Swema 3000md is used to measure the over / under pressure in the room / channel, connect the pressure hose on positive pressure connector (marked with +). The externally connected differential pressure probe (SWA 07/SWA 10) is used to measure the leakage flow, connect the pressure hose on negative pressure connector (marked with -).

Connect the cable from the leakage tester to the RS232 contact on Swema 3000md. Select measurement House (building / room measurement) in MENU1.

K-factor

Set the K-factor as marked on your orifice plate on leakage tester. The orifice plate has 2 different K-factors depending on which way the air direction i.e. if you are measuring over- or underpressure. The K-factors are marked on orifice plate with arrows to indicate the direction. The air direction are also shown in the menu on Swema 3000md as arrows. Use the UP/ DOWN-arrow keys to change the K-factor. Press SELECT to either change the "Forward K-factor" --> or "Reverse K-factor" <--.

Unit

There are 4 units to choose from: l/s, m³/h, l/sm² or m³/hm². l/sm² or m³/hm² is the relationship to the surface area on the object leakage tested.

Pressure Step

Here you set the step size of Pa as you wish Swema 3000md will change when measuring. If 10 Pa is set, the desired pressure will increase or decrease by 10 Pa at the time, i.e. at an increase it will start at 0 Pa and continue in increments of 10, 20, 30 Pa, etc..

I-factor

Swema 3000md uses a PID-regulation to control the fan. Here another I-factor can be set if desired.

Set Parameters

Here a number of external parameters are set. NOTE! only the "Area" can have an effect on the measurement result, the other parameters are stored only in the saved protocoll.

Parameters

Indoor: Current temperature of the room

Outdoor: Outdoor temperature

Wind: The wind outdoors

Area: Surface area (the area set here will be used for calculation of the units l/sm² and m³/hm²).

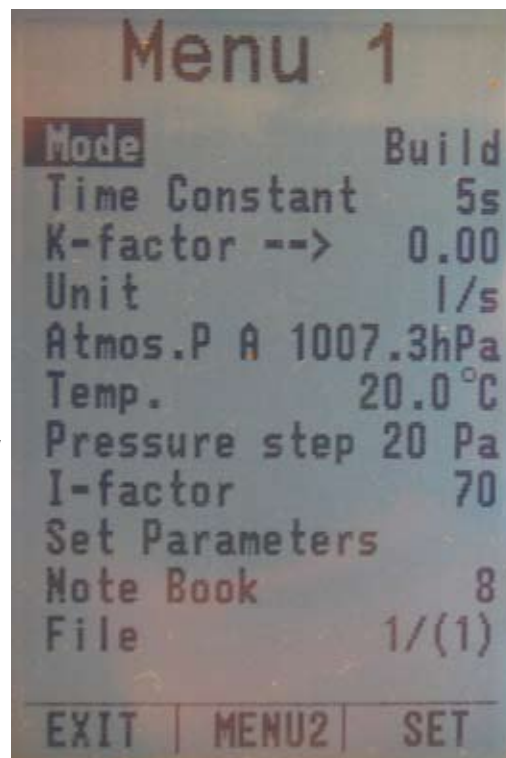

Set the Mode to Build in Menu1. Set the "Forward K-factor" (-->) and "Reverse K-factor" (<--) according to the marking on your orifice plate. Also set the unit you want to show your measured values in.



If you press on "Set Parameters" this window will be displayed. Here the indoor and outdoor temperature, the wind outdoors and surface area can be set. The area set here will be used for calculation of the units l/sm² and m³/hm².

Make a measurement

When measuring Swema 3000md should be set to measure with the external pressure probe, "INT." should be shown in the square to the left of the Menu-keys (it is also possible to measure with the internal pressure sensor, but then the pressure hoses must be changed).

Before you start measuring both differential pressure probes must be zeroed. Press INT. to access the built-in pressure probe in Swema 3000md, press "ZERO". Press on EXT. to go back to the externally connected pressure probe and zero it. In measuring mode the display will show 4 measuring parameters. The largest digits at the top are the leakage flow (l/s, m³/h, l/sm² or m³/hm²) and below the leakage flow is the pressure drop over the orifice plate which is used to calculate the leakage flow. The two pressures that are displayed with small digits at the bottom is: to the left the setpoint (the pressure you want to achieve) and to the right is the true value (the pressure you measure in reality).

Measurement can be done either manually or automatically.

Manually

When Swema 3000md in measuring position, you can use the UP/DOWN-arrow buttons to choose a pressure setpoint that you want the fan to achieve. When pressing the UP/DOWN buttons the setpoint value will increased/decreased in steps according to what is set in "Pressure Step" in MENU1. The leakage tester will automatically stabilize at your desired setpoint and the leakage flow can be read.

Automatically

The automatic measurement consists of 3 phases. First the over/under pressure in the room to be tightness tested is measured. This is done by inserting a sealing balloon into the opening of the orifice plate, the pressure shown direct under the leakage flow is the over/under pressure. Press the ENTER button and Swema 3000md will make an average of pressure over 20 seconds. When it is done use the UP / DOWN buttons to set the pressure where you want to start measuring at. Press the ENTER button and Swema 3000md will regulate itself and save the measured values at the different pressures going down or up to 0 Pa. The pressure steps Swema 3000md do on the way to 0 Pa, is set in Menu1 under "Pressure Step". Once then measurements are completed the over/under pressure should be measured again in exactly the same way as the first time, insert a sealing balloon into the orifice plate and press ENTER button.

When it's done, you are asked if you want to save the measured values, press Save and the measurements are saved in the Note Book.

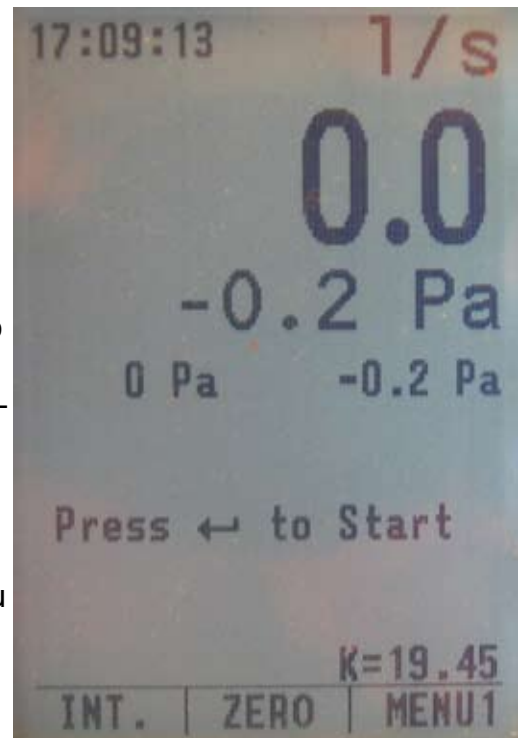

Measuring mode for leakage testing of building. Make sure that both the differential pressure probes are zeroed. Use the UP/DOWN buttons to measure manually. Press ENTER button to start an automatic measurement and as a first step measure the over/under pressure.



Saved measuring protocol of a leakage test on a room or building.

Leakage tester for Duct

To control the leakage tester automatically a Swema 3000md and a SWA 10 or SWA 07 are needed. The built in differential pressure sensor in Swema 3000md is used to measure the over / under pressure in the room / channel, connect the pressure hose on positive pressure connector (marked with +). The externally connected differential pressure probe (SWA 07/SWA 10) is used to measure the leakage flow, connect the pressure hose on negative pressure connector (marked with -).

Connect the cable from the leakage tester to the RS232 contact on Swema 3000md. Select measurement DUCT in MENU1.

K-factor

Set the K-factor you have on your orifice plate on the leakage tester.

Area

Set the surface area you have in the duct that you wish to test. The area set here is used to calculate l/sm^2 and m^3/hm^2 if this unit is selected

Tightness Class

Set here the density class you want to test the duct against. You can choose between Class A, B, C or D. In the saved protocol your choice of class will be used to calculate and show the limit for the leakage of your test. The limit depends on which class you choose and at what pressure you test at.

Unit

There is 4 different measuring units to choose from: l/s , m^3/h , l/sm^2 or m^3/hm^2 . l/sm^2 and m^3/hm^2 is calculated by the surface area set under Area.

I-factor

Swema 3000md uses a PID-regulation to control the fan. Here another I-factor can be set if desired.

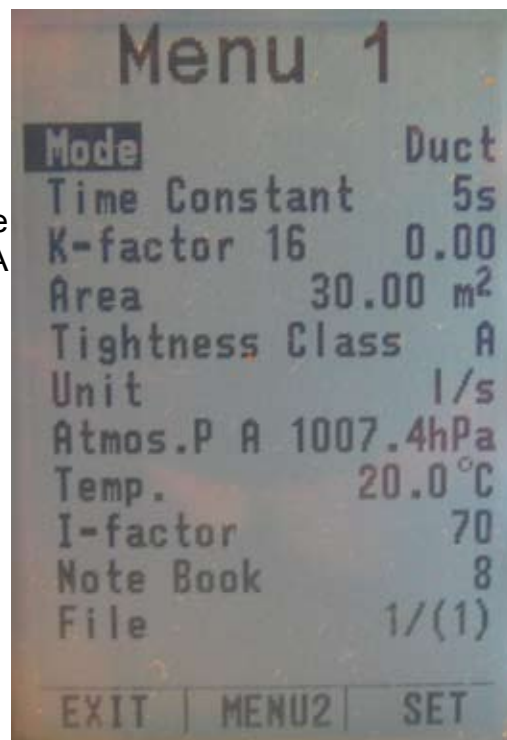

Mode	Duct
Time Constant	5s
K-factor	16 0.00
Area	30.00 m ²
Tightness Class	A
Unit	l/s
Atmos.P	A 1007.4hPa
Temp.	20.0 °C
I-factor	70
Note Book	8
File	1/(1)

EXIT | MENU2 | SET

Set the Mode to Duct in Menu 1.

Set the K-factor you have on your orifice plate. Also set the surface area, tightness Class and the unit you want to show your measured values in. The surface area you set will be used to calculate the units l/sm^2 and m^3/hm^2 .

Make a measurement

When measuring Swema 3000md should be set to measure with the external pressure probe, "INT." should be shown in the square to the left of the Menu-keys (it is also possible to measure with the internal pressure sensor, but then the pressure hoses must be changed).

Before you start measuring both differential pressure probes must be zeroed. Press INT. to access the built-in pressure probe in Swema 3000md, press "ZERO" . Press on EXT. to go back to the externally connected pressure probe and zero it. In measuring mode the display will show 4 measuring parameters. The largest digits at the top are the leakage flow (l/s, m³/h, l/sm² or m³/hm²) and below the leakage flow is the pressure drop over the orifice plate which is used to calculate the leakage flow. The two pressures that are displayed with small digits at the bottom is: to the left the setpoint (the pressure you want to achieve) and to the right is the true value (the pressure you measure in reality).

Use the UP / DOWN buttons to change the setpoint to the pressure you want to measure at, wait until Swema 3000md has stabilized the true value at that pressure. Make a measurement by pressing the ENTER button.

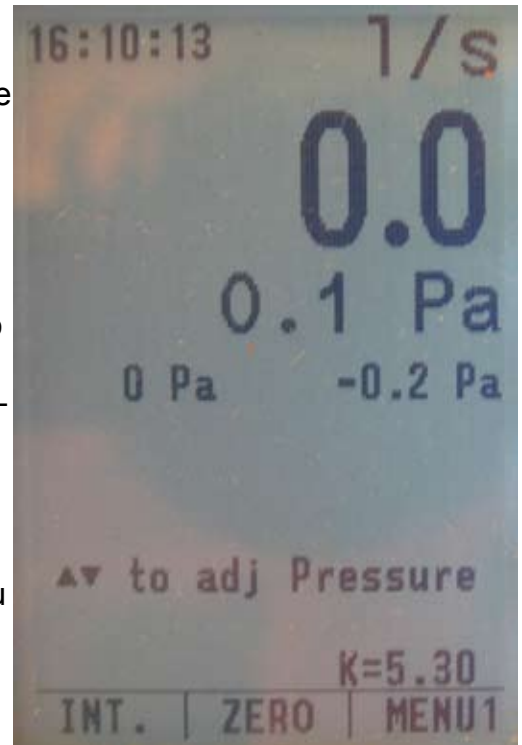

Measuring mode for leakage testing of ducts. Make sure that both the differential pressure probes are zeroed. Use the UP/DOWN buttons to choose the set point you want to measure at. Press ENTER button to make a measurement.

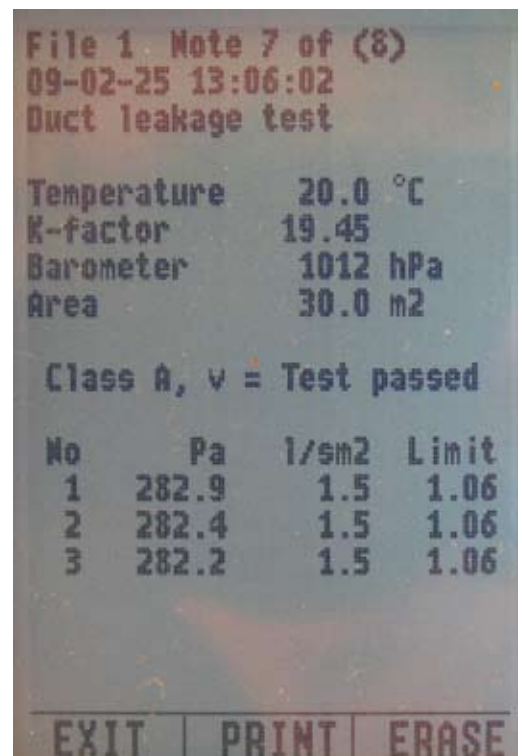

In the saved protocol your choice of class will be used to calculate and show the limit for the leakage of your test. The limit depends on which tightness class you choose and at what pressure you test at.

Control unit for leakage tester



Potentiometer

Standby

Press this button to stop the auto and manuall control and put the control unit in standby.

Automatic control

Press this button for autmatic control by Swema 3000md.

Manual control

Press this button if you wish to control the leakage tester manually with the potentiometer.

If the power cable is unplugged and the standby (Off reset) button has not been pressed the control unit will remember the last used control alternative. So when the power cable is plugged in again the control unit will go to either automatic or manual mode depending on what was last used.

Measuring with SwemaTwin - Balancing of ventilation

Connect 1 modem each to 2 Swema 3000 or a long cable in between the 2 Swema 3000:s.
Always start by turning on the master first and select a mode that shows flow DPF, AF or APF.
To get the relations in % you need to have the same unit on both instruments. If you have the 4000mAh modems you also have to start them manually.

Change in MENU2 as following:

Master unit (the instrument you bring with you)

"Swema Twin" set to **On**

"Communication" set to **RS232**

"Baud Rate" set to **4800**

Reference unit (the instrument you leave at the reference valve)

"Swema Twin" set to **Off**

"Communication" set to **RS232**

"Baud Rate" set to **4800**

When measuring, the Master shows the flow of both the Master and the Reference. It also shows the relation: Master in % of the reference instrument: $(\text{Master} / \text{Reference}) * 100\%$.

The relation is very handy when doing ventilation system adjustments according to the proportional method.

Balancing a ventilation system according to the Proportional method:

First decide where to place the reference instrument. The flow according to the drawing at this place is the nominal reference flow. The other measurement points are adjusted with the Master instrument. We call these nominal flow values from the drawing nominal Master flows.

Calculate for each Master measurement point:

$(\text{nominal Master flow} / \text{nominal reference flow} * 100)$.

These are the relations that you shall obtain when you have balanced two diffusers/inlets/outlets. Measure with the reference instrument on the reference in/outlet and the Master instrument on the in/outlet you want to adjust. The relation is important and not the actual flow. The final flows will occur when the final adjustment of the total flow in the ventilation system is done.

When no connection is establish between the Master and Reference instruments show "----".

Charging of modem: Connect first the charger to the net plug. Thereafter to the batteries. The battery packs delivered by Swema supply the Swema 3000 with power. One charge is good for 5-10 hours use with 1800mAh battery and 10-20 hours use with 4000mAh battery. For the 1800mAh battery pack: If charger is constantly lit the charging is going on. If the charger blinks - battery is only trickle charging. If this happens too early (after 0,5 hours) you need to start charging once more.

Swema 3000 has three menus to input measurement settings and parameters.

Menu 1

Atmospheric pressure is used when Swema 3000 does calculations for air velocity and air flow.

Swema 3000 is available in three different models, Swema 3000d with a built in barometer, Swema 3000md with built in barometer and differential pressure probe or Swema 3000 without barometer and differential pressure probe.

In Swema 3000 the atmospheric pressure can be set manually by moving the marker to "Atmos.P" with the UP/DOWN-arrow key. Press ENTER or SET and set the actual atmospheric pressure with the UP/DOWN-arrow key and alter digit position with LEFT/RIGHT-arrow key. Confirm your choice with ENTER or EXIT.

Swema 3000d / md automatically compensates for the air density (atmospheric pressure and temperature). To turn of the automatically compensation for the barometric pressure and set it manually set "Atmos.P" to "M" (Manual) instead of "A" (Automatic).

Temperature is used when Swema 3000 does calculations for air velocity and air flow. Swema 3000d / md has an extra temperature thermocouple input. Swema 3000 is without this connector.

All Swema 3000 are temperature compensated when a probe with a built in temperature sensor is connected. Such as hot wire anemometer, flow capture, draught probes and relative humidity and temperature probes.

When a differential pressure probe (SWA 10 or 07) is connected to Swema 3000d or when Swema 3000md is used the measurement is automatically temperature compensated for the correct temperature when a thermocouple probe is connected. The thermocouple must be connected when you turn the instrument on otherwise no temperature will be measured.

In Swema 3000 the temperature can be set manually when a differential pressure probe is connected. Move the marker to "Temp" with the UP/DOWN-arrow key. Press ENTER or SET and choose temperature with the arrow keys and alter position with LEFT/RIGHT-arrow key. Confirm your choice with ENTER and press Enter or EXIT to confirm. or EXIT.

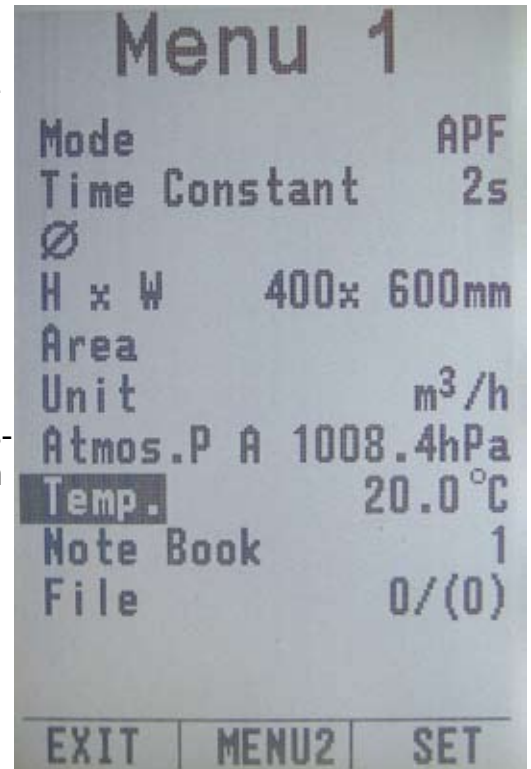

Highlight the parameter you want to change and press Enter or SET.

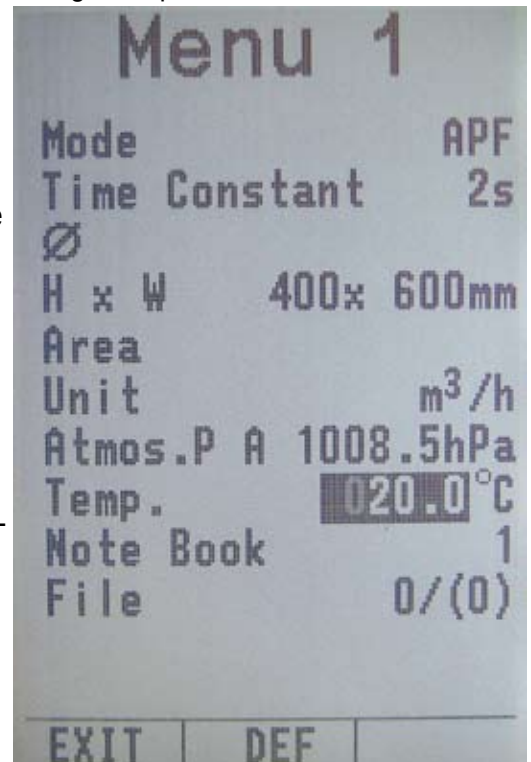

Change the parameter with the arrow keys and press Enter or EXIT to confirm.

Menu 2

Swema Twin	ON or OFF Only when you use SwemaTwin, set ON at your master unit
Communication	USB or RS232 Communicate via USB (cable 764.430) or RS232 (cable 759.030) to your PC.
Baud Rate	2400, 4800, 9600, 19200 or 57600 Normally 4800 for SwemaTwin, 9600 for PC-transfer (RS232 cable).
Add Flow	ON or OFF If set to ON. Swema 3000 will add the flow from each measurement in one file and present a total flow.
Protocol	SHORT or LONG Here you specify if you want a long or short protocol (note) at PC-printout.
1 Unit Decimal	0, 1, 2, 3 or 4, Select number of decimals for the big digits. The number of decimal on the display will be according to what you choose here until a fifth digit is needed. The display can only show four big digits on the same row at the same time. Because of this one decimal will disappear. When saving a measured value the number of decimal will be the same as shown on the display.
2 Unit Decimal	0, 1 or 2, Select number of decimals for the small digits
Auto Zero	ON or OFF When you have a SWA 10 pressure probe connected or uses a Swema 3000md you can choose automatic zeroing when you collect values.
k₂ Factor	ON or OFF Set ON if you want Swema 3000 to calculate with a k ₂ -factor. See APF mode. ON: Flow = air velocity * k ₂ * area OFF: Flow = air velocity * area

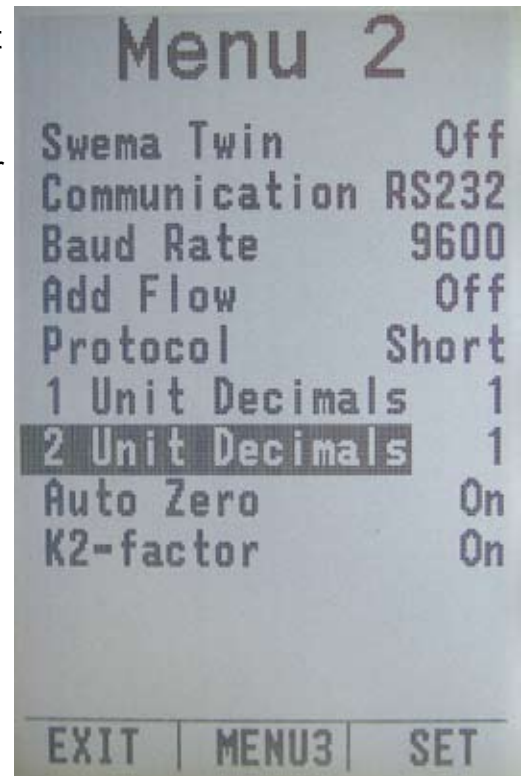

Move in the menu with the up/down arrow keys. Press Enter, Set or right arrow key to select.

Menu 3

Time/Date	Set clock/date
Adjust Clock	Set a value to compensate the clock error
Auto off	Set the automatic shut down time
Unit System	SI or US Set which units you want to use Metric (SI) or American (US).
Contrast	Set display constast
Print Out	Select if you want comma or point separation at PC-print out. Excel uses either comma or point.
Language	English, German, Swedish, Finnish, French, Danish, Norwegian, Dutch or Polish. Set the language you wuold like to use.



Change with the up/down arrow keys.

SwemaTerminal

Swema Terminal is a freeware (No free support) that can be downloaded at www.swema.com. SwemaTerminal works with both USB and RS232 communication, baudrate is 9600bits/s.

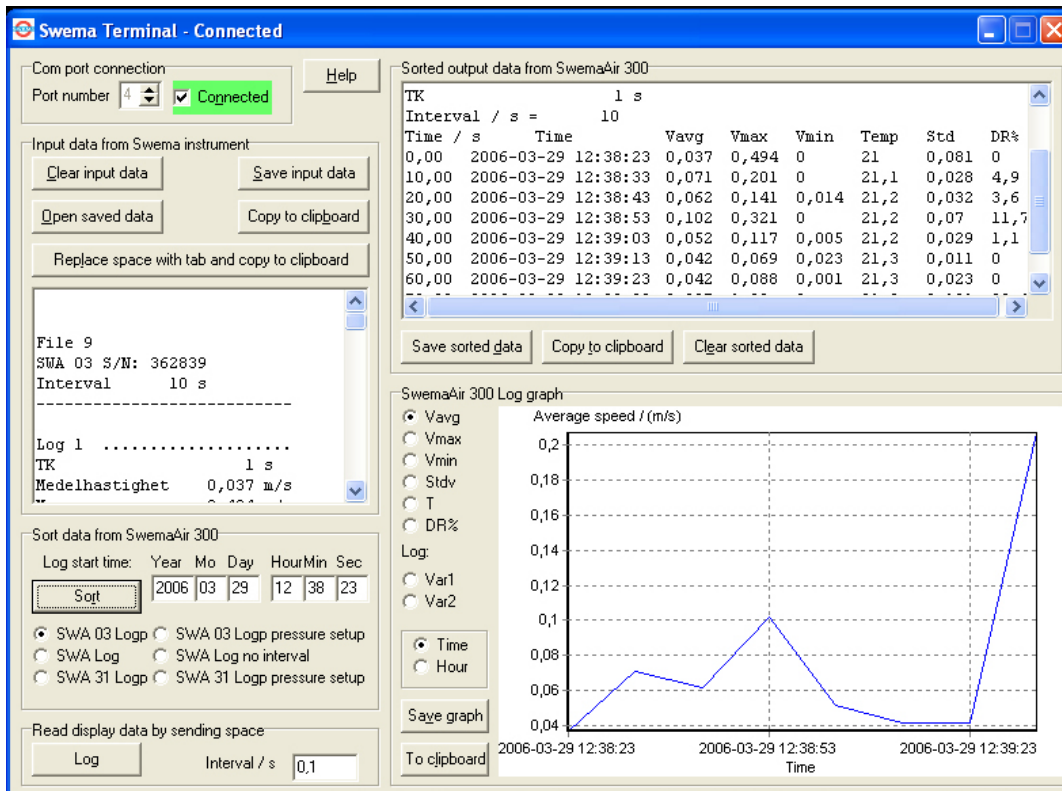

SwemaTerminal reads data from Swema instruments through the serial port on the chosen COM port. SwemaTerminal makes it easy to copy and paste data into Word, Excel or other programs.

In the settings of the Swema 3000 the baud rate must be set to 9600 bits/s. Select the chosen COM number. Click on 'Connected' to open the port. Press the 'Print' button on the Swema 3000 when you are in the Note book or File Menu. See also Note Book, Log Book and File in this manual. The data will be read and added to the bottom of the text window to the left. This text can be saved, copied to the clipboard or cleared. It is also possible to open earlier saved data. The data can be edited in this window.

The button 'Log' in the lower left corner instructs the Swema 3000 to send the display values at selected interval by, the lowest interval you can choose is 10Hz (0,1s).

The right part (sorting and graphs) of SwemaTerminal can't be used with Swema 3000 only SwemaAir 300.

SwemaUSB

SwemaUSB is a PC-program that can be used to data transferring and updating of firmware in Swema 3000 (contact Swema for possible firmware update). SwemaUSB and driver for USB communication is delivered together with Swema 3000 on the CD.

Follow the instructions on the CD how to install the program and USB driver. Set Swema 3000 to USB communication in MENU2 and connect the USB cable to the computer. Start SwemaUSB and turn the instrument on, in SwemaUSB you don't need to choose any COM-port.

Your saved measurement can be printed to the computer as described in the chapter Note Book, Log Book and File.

If you press Enter on the computer keyboard or holds down the ENTER-button on Swema 3000 when you turn the instrument on the calibration protocol of the connected probe will be printed to the computer.

If you press "space" on the computer keyboard the displayed value will be printed.

If you press "v" on the computer keyboard or holds down LEFT-button on Swema 3000 when you turn the instrument on the protocol for the instrument and possible barometer will be printed.

Time constant

The Swema 3000 always measures continuously with the internal instrument sampling rate of 40Hz.

Differential pressure probes and all other probes when measuring in LOG and LOGP

The displayed value is an average made from the measured values during the time constant. When logging with LOG or LOGP or measuring with differential pressure probes below 0.4 Pa and with a Time Constant set to 0.25 seconds the actual Time Constant is 4 seconds.

Below 0.4 Pa and with a Time Constant set between 0.5 and 8 seconds the actual time constant is 8 seconds.

All probes (not differential pressure probes) except when you are in LOG and LOGP

The measured values are filtered before they are displayed. After a period equal to the Time Constant 90% of a change to an end value is displayed. After 1.5 x Time Constant 99% of the end value is displayed. After 1.8 x Time Constant 99.9% of the end value is displayed.

General

The displayed value are updated every 0,5s except when the time constant is 0.25 or 0.1 second. Then the display is updated at this rate.

For the SWA 03 draught probe the time constant is always 0,1 second.

The displayed values are also the values that are used to calculate the average, max, min, standard deviation in AP, APF, DPF, LOG and LOGP mode. In CO mode 0,1 second averages are used to present these values.

Displayed values and saving measurement

Small and big digits

When in measuring mode both small and big digits can be used. Normally big digits are used but sometimes the display changes and shows small digits instead. The small digits will be displayed when the time constant is set to 0.1s or when the displayed value don't fit, i.e. a positive value with more than 5 digits or a negative value with more than 4 digits.

Number of decimals

Number of decimals shown in the display are according to what is set in MENU" until a 5:th digit are needed, then one decimal disappears because the display can only show 4 big digits. When saving a value the number of decimal saved is the same as displayed.

Saving in APF and DPF mode

If Swema 3000 with an inbuilt barometer and thermoelement is used (Swema 3000d and Swema 3000md), the displayed Avg, Max and Min values are then calculated by the barometric pressure and temperature value at the different measuring points. When saving the measurement an average value of the barometric pressure and temperature will be saved. The average values will then be used to calculate the saved values in the Note book.

Technical Data

The uncertainty of measurement for each probe is stated below as the uncertainty for the probe together with a calibrated Swema 3000. The uncertainty is stated with coverage probability of 95%. Included in the uncertainty for each probe is the uncertainty for Swema 3000, interchangeability, calibration, temperature dependence, hysteresis and repeatability.

The user should correct the measured values with the correction on the probe calibration protocol to obtain stated accuracy.

Swema 3000 instrument:

Instrument temperature:	0...+50°C
Memory capacity, Note book - Log book:	approx. 1 600 notes or 14 000 pairs of values or 20 000 single values
Interchangeability accuracy:	Negligible in relation to accuracy of probes.
Digital Output:	RS232, send ":" or "Space". Swema 3000 sends the displayed value (big digits) or (big and small digits) Transmitting rate max 10 times/second (Time constant 0.1s) USB
Battery:	2 x 1,5V AA
Battery life with SWA 31 at 1 m/s:	13 hours with NiMH, 17 hours with alkaline Use the 230V-adaptor (764.610) for continuous operation.
Battery with backlight on:	5,5 hours with NiMH, 8,5 hours with alkaline
Instrument Calibration:	Recommended every 5 year
Only on Swema 3000d part no. 764.201 and Swema 3000dm part no. 764.202	Barometer 600...1200hPa, $\pm 2,5$ hPa Thermo couple Type K -270...1370°C $\pm 0,3$ °C at -10...70°C

Draught probe, SWA 03:

Measuring range of velocity	0,05...3,0 m/s at +10...+34°C
Measuring media	Dry and moist air, non-aggressive gases
Accuracy (m/s) at 23°C:	$\pm 0,03$ m/s at 0,05... 1,00 m/s
at 10...34°C:	$\pm 3\%$ read value at 1,00...3,00 m/s $\pm 0,04$ m/s at 0,05... 1,00 m/s $\pm 4\%$ read value at 1,00...3,00 m/s
Response time of velocity sensor:	0,2 sec.
Measuring range of temperature:	+10...+40°C
Accuracy (°C):	$\pm 0,3$ °C at 20°C $\pm 0,5$ °C at 10...+40°C
Probe Calibration:	Recommended every 6 months.

Air velocity probe, SWA 31:

Ø8mm at top, Ø10mm first step on telescope (handle)

Measuring media Dry and moist air, non-aggressive gases

Measuring range of velocity 0,1...30 m/s at -10...+45°C

Accuracy (m/s) at 20°C: 0,10...1,33 m/s ±0,04 m/s
1,33...30 m/s ±3% of read value
at other: 0,10...1,10 m/s ±0,05 m/s
1,10...30 m/s ±4,5% of read value

Measuring range of temperature: -20...+80°C

Accuracy (°C): ±0,3°C at 20°C
±1,0°C at -20...+80°C

Probe Calibration: Recommended every 12 months.

Pressure probe

SWA 10:

SWA 07:

Swema 3000md:

Pressure range: -300...1500Pa ±7 000 Pa

Max. overload: ±20 000 Pa ±35 000 Pa

Accuracy: ±1% read value ±1 Pa ±2% read value
md: ±0,3% read value After zeroing:
Minimum 0,3Pa ±0,3 Pa ±2% read value

Temperature dependence: 0,2Pa/°C 0,4 Pa/°C

Long-term stability,
Zero point: 0,1 %Full scale /year - avoid by zeroing probe
Full measuring range: 0,1 %Full scale /year

Measuring media: Dry and moist air, nonaggressive gases

Probe Calibration: Recommended every 12 months.

Temperature SWA 25 / 53 / SWT 315 / 215 / 221:

Measuring range (probe depending): -50...+280°C
Interchangeability accuracy: max ±0.1°C

Probe Calibration: Recommended every 24 months.
Sensors: According DIN 43760 (approx. ±0.5 °C
at room temperature.)

SwemaFlow 125:

Flow measurement range:	2-125 l/s (7 - 450 m ³ /h) The instrument always displays 0 when the flow is below 2 l/s (7 m ³ /h).
Measuring media:	Air, non-aggressive gases
Accuracy (l/s, m ³ /h):	ca ± 3% read value, min ± 1 l/s
Temperature range	-10...+50 °C
Accuracy (°C):	± 0.3 °C at 20 °C ± 0.5 °C at other
Probe Calibration:	Recommended every 6 months.

Battery:

In the Swemaflow 125 there is a rechargeable battery pack of nickel-metal-hydride type (NiMH). A full charged battery last a normal working day. At high Air flow it may last a shorter time.

Indication when battery has to be recharged.

When the battery is nearly empty the battery symbol on the Swema 3000 blinks. When the battery is completely empty the Swema 3000 turns itself off. (When the Swema 3000 battery is nearly empty the battery symbol is continuously lit. When the battery is empty Swema 3000 turns itself off.)

Charge the battery

Use the charger that is delivered together with the SwemaFlow 125. Do not use another charger which may be dangerous.

Connect first the charger to a wall connector and secondly to the SwemaFlow 125. A red diod is lit on the SwemaFlow 125 when charging. The red diod is blinking when the battery is to warm or cold. Disconnect and wait until the temperature is between 10 and 45°C. When the battery is fully charged the red diod turns off. (blinks on older version, 2005).

It takes one hour to charge the battery.

Swema recommends to wait about half an hour before measuring after charging the battery (The diod has turned off) to let the SwemaFlow 125 cool down.

The battery is protected from over charging and when the battery is charged, trickle charging will go on until the battery charger is disconnected.

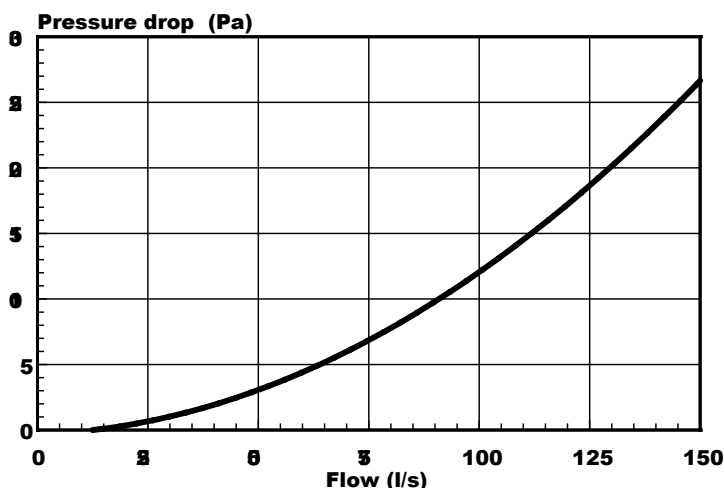

SwemaFlow 65:

Flow measurement range:	2-65 l/s (7 - 230 m ³ /h) below 2 l/s the instrument displays 0. Above 65 l/s the display blinks - then the value is uncertain.
Measuring media	Dry and moist air, non-aggressive gases
Accuracy at 18...30°C:	± 4% read value, minimum ± 1 l/s
at 10...18, 30...40°C:	± 6% read value, minimum ± 1 l/s
Probe Calibration:	Recommended every 6 months.

Battery:

The Swemaflow 65 has a rechargeable nickel-metalhydrid (NiMH) battery pack. A full charged battery last a normal working day. At high Air flow it may last a shorter time. When the battery is nearly empty the battery symbol on the Swema 3000 blinks and the red diod on SwemaFlow 65 is shut off. When the battery is completely empty the Swema 3000 turns itself off. Use the charger that is delivered together with the SwemaFlow 65. Do not use another charger which may be dangerous. It takes approx. 3 hours to charge the battery. The battery is protected by over charging and it may also be charged before it is empty.

SwemaFlow 2000:

Flow measurement range:	4-900 l/s (15 - 3240 m ³ /h) below 4 l/s the instrument displays 0.
Temperature range:	-10...+50 °C
Measuring media:	Dry and moist air, non-aggressive gases
Accuracy:	± 4% read value, minimum ± 1 l/s ± 0,3°C at 20°C, ± 0.5°C at -10...+50°C
Probe Calibration:	Recommended every 6 months.
Battery charge time:	about 2 hours

Weight including flow capture 650x650mm: 3,9 kg
(4,3 kg including the Swema 3000)

Battery: It takes two hours to charge the battery. See SwemaFlow 2000.

Humidity and Temperature SWA 12-13 and 16 + cable and Hygroclip + cable:

Relative Humidity range:	0...100%RH
Measuring media:	Dry and moist air, non-aggressive gases
Accuracy SWA 12...13 and 16 at 23°C:	± 1,6%RH at 10...90%RH others ± 2,6%RH
Hygroclip at 23°C:	± 1,6%RH at 0...100%RH
Temperature range SWA 12...13:	-20...+60 °C
SWA 16:	-20...+150 °C
Hygroclip S (other models):	-40...+85°C (-50...+200°C)
Accuracy temperature:	± 0,3 °C
Probe calibration:	Recommended each 12 months.
Calculations:	Dew Point and Mixing Ratio (g water / kg dry air)